



SolarEdge Safety and Monitoring Interface Installation Guide

Version 2.1

Disclaimers

Important Notice

Copyright © SolarEdge Inc. All rights reserved.

No part of this document may be reproduced, stored in a retrieval system or transmitted, in any form or by any means, electronic, mechanical, photographic, magnetic or otherwise, without the prior written permission of SolarEdge Inc.

The material furnished in this document is believed to be accurate and reliable. However, SolarEdge assumes no responsibility for the use of this material. SolarEdge reserves the right to make changes to the material at any time and without notice. You may refer to the SolarEdge web site (www.solaredge.com) for the most updated version.

All company and brand products and service names are trademarks or registered trademarks of their respective holders.

Patent marking notice: see www.solaredge.us/groups/patent

Exclusion of Liability

The general terms and conditions of delivery of SolarEdge shall apply.

The content of these documents is continually reviewed and amended, where necessary. However, discrepancies cannot be excluded. No guarantee is made for the completeness of these documents.

Emission Compliance

This equipment has been tested and found to comply with the limits applied by the local regulations. These limits are designed to provide reasonable protection against harmful interference in a residential installation. This equipment generates, uses and can radiate radio frequency energy and, if not installed and used in accordance with the instructions, may cause harmful interference to radio communications. However, there is no guarantee that interference will not occur in a particular installation. If this equipment does cause harmful interference to radio or television reception, which can be determined by turning the equipment OFF and ON, you are encouraged to try to correct the interference by one or more of the following measures:

- Reorient or relocate the receiving antenna.
- Increase the separation between the equipment and the receiver.
- Connect the equipment into an outlet on a circuit different from that to which the receiver is connected.
- Consult the dealer or an experienced radio/TV technician for help.

Changes or modifications not expressly approved by the party responsible for compliance may void the user's authority to operate the equipment.

Support and Contact Information

If you have technical queries concerning our products, please contact us:

US & Canada	1877 360 5292	support@solaredge.us
Japan	+81.3.5530.9360	japan-info@solaredge.com
Germany	+49 89-45459730	support@solaredge.de
France	0800917410	support@solaredge.fr
Belgium	080073041	support@solaredge.be
Italy	800 784 824	support@solaredge.it
Netherlands	08000221089	support@solaredge.com
United Kingdom	08000281183	
Greece	00800125574	
Israel	+972 73 240-3118	
Australia	1800465567	
Worldwide	+972 73 240-3118	
Fax	+972 73 240-3117	

Before contact, ensure you have the following information at hand:

- SMI and power optimizer model
- Inverter model and specifications
- Serial number of the SMI and the power optimizer in question
- The error indicated on the SMI screen or on the SolarEdge monitoring portal
- System configuration information, including the type and number of modules connected and the number and length of strings
- The communication method to the SolarEdge server
- The SMI firmware versions

Table of Contents

Disclaimers	1
Important Notice	1
Exclusion of Liability.....	1
Emission Compliance	1
Support and Contact Information	2
Table of Contents	3
Handling and Safety Instructions	5
Safety Symbols.....	5
Instructions	5
Chapter 1: Introduction to the SolarEdge Safety and Monitoring Interface	6
Overview.....	6
Installation Workflow	7
Installation Equipment List	8
Chapter 2: Installing the Safety and Monitoring Interface	9
SMI Transport and Storage	9
SMI Package Contents	9
Identifying the SMI	9
Mounting the SMI.....	9
SMI Connectors.....	10
Connecting the SMI to AC.....	11
Chapter 3: Connecting PV Strings to the Safety and Monitoring Interface	13
Overview.....	13
Chapter 4: SMI User Interface	16
External Interface - LCD, LEDs and LCD Light Button	16
Internal Interface - The LCD User Buttons	17
Setup.....	18
Configuring the SMI Using the LCD User Buttons	18
Configuring the SMI Using the LCD Light Button	19
SMI Configuration Menu Options.....	21
Operational Mode – Status Screens.....	24
Initial SMI Status	24
Telemetry.....	24
ID Status	24
Server Communication Status	25
IP Status	25
ZigBee Status.....	25
Communication Ports Status Window.....	25
Chapter 5: Commissioning the Safety and Monitoring Interface	27
Step 1, Activating the System	27





- Step 2, Pairing Power Optimizers to the SMI28
- Step 3, Verifying Proper Operation29
- Step 4, Reporting and Monitoring Installation Data29
 - The SolarEdge Monitoring System29
 - Providing Installation Information30
- Chapter 6: Connecting the Inverter..... 31**
 - Step 1, Connecting the inverter to the SMI31
 - Step 2, Verifying Proper Operation32
- Chapter 7: Setting Up Communication..... 33**
 - Communication Dataflow33
 - Communication Types33
 - Communication Connectors34
 - Creating an Ethernet (LAN) Connection.....35
 - Overview35
 - Ethernet Communication Configuration Options35
 - Connecting and Configuring LAN36
 - Interfacing with Other Devices Using an RS485 Bus39
 - Overview39
 - RS485 Configuration Options39
 - Creating an RS485 Bus Connection40
 - Connecting to Non-SolarEdge Inverters via RS48543
 - Additional Connection Options.....44
 - Creating a Wireless ZigBee Connection44
 - Creating an RS232 (UART) Connection44
 - Connecting a Laptop to the SMI44
 - Verifying the Connection45
- Appendix A: Errors and Troubleshooting 46**
 - S_OK Not Displayed46
 - Troubleshooting General Errors46
 - Troubleshooting Communication47
- Appendix B: Technical Specifications 49**
- Appendix C: Mechanical Specifications 50**
- Appendix D: Opening and Closing the SMI Cover 51**

Handling and Safety Instructions





During installation, testing and inspection, adherence to the following handling and safety instructions is mandatory.

Safety Symbols

The following safety symbols are used throughout this document.

	WARNING! Denotes a hazard. It calls attention to a procedure that, if not correctly performed or adhered to, could result in injury or loss of life . Do not proceed beyond a warning note until the indicated conditions are fully understood and met.
	CAUTION: Denotes a hazard. It calls attention to a procedure that, if not correctly performed or adhered to, could result in damage or destruction of the instrument . Do not proceed beyond a caution sign until the indicated conditions are fully understood and met.
	NOTE: Denotes additional information about the current subject.
	IMPORTANT SAFETY FEATURE: Denotes information about safety issues.

Instructions

	WARNING! Do not remove the SMI cover before five minutes have elapsed after disconnecting all sources of power. Only use lockable connectors for DC connection. Otherwise, there is a risk of electric shock from energy stored in the capacitor.
	WARNING! Before operating the SMI, ensure that the power cable and wall outlet have been grounded properly.
	WARNING! Opening the SMI and repairing or testing under power must be performed only by qualified service personnel familiar with the SMI.
	WARNING! SMI is configured to IndOP mode and NOT to SolarEdge fixed string voltage mode. Therefore, string lengths and system design must comply with the inverter design guidelines. SolarEdge extended string lengths are not applicable. Designing outside of the inverter design rules may result in permanent damage to the inverter.
	CAUTION: This unit must be operated under the specified operating conditions as described in <i>Appendix B: Technical Specifications</i> on page 47.

Chapter 1: Introduction to the SolarEdge Safety and Monitoring Interface

Overview

When connecting SolarEdge power optimizers to a non-SolarEdge inverter, the SolarEdge Safety and Monitoring Interface (SMI) device enables the following features:

- Safety functions of the optimizers.
- Communication of the module-level data sent from the optimizers to the SolarEdge monitoring portal.

The SMI is installed between the SolarEdge power optimizers and a non-SolarEdge inverter. The SMI is compatible with any on-grid inverter. For some inverters, it may also serve as the inverter data logger, which monitors power optimizers and inverter data in a single location – the SolarEdge monitoring portal*.

The SMI supports the optimizer SafeDC™ feature. The SafeDC™ mechanism automatically shuts down module voltage whenever the grid power is shut down, thus providing greater safety during installation, maintenance and firefighting.

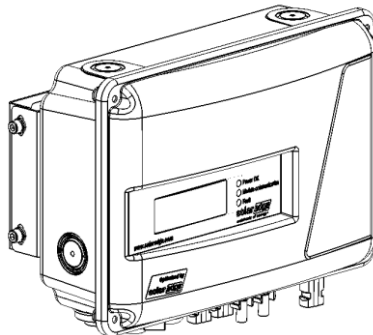
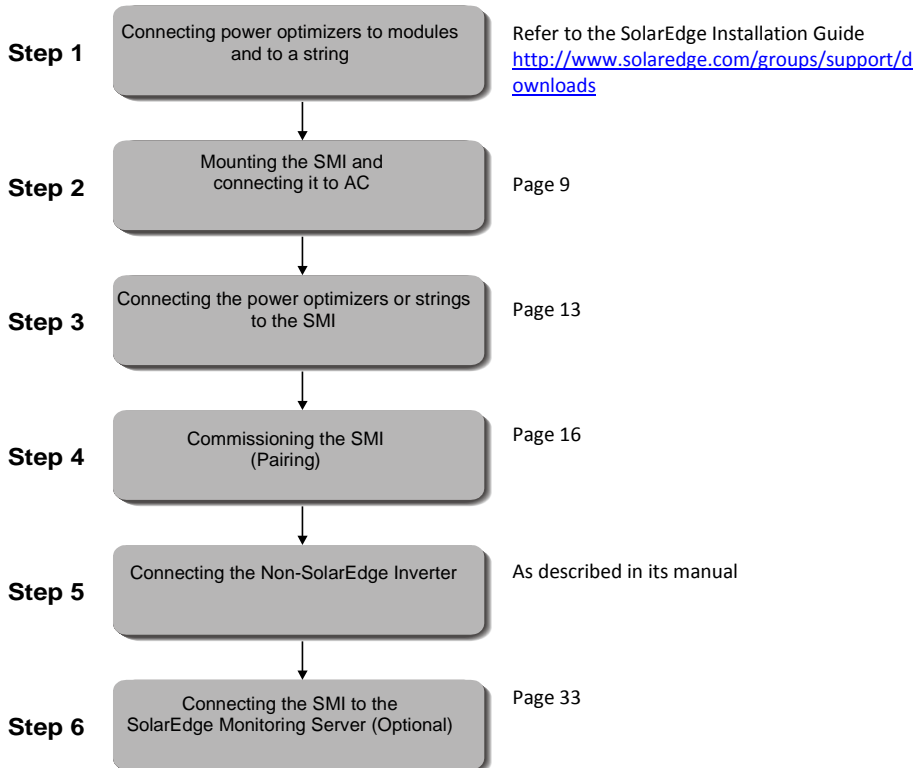

Figure 1: The SolarEdge Safety and Monitoring Interface (SMI)

* For a complete list of compatible inverters that can be interfaced to the SMI, refer to <http://www.solaredge.com/articles/se-smi-compatible-inverters>.

Installation Workflow

The following provides an overview of the workflow for installing and setting up a new site. Most of these procedures can also be used for adding components to an existing site.



Installation Equipment List

Standard tools can be used during the installation of the SolarEdge system. The following is a recommendation of the equipment to be used:

- Allen screwdriver
- Standard flat head screwdriver
- Flat Head screwdriver for P25 screws (watchmaker's screwdriver)
- Screwdriver for ¾" metal lock nut
- Electrical screwdriver (tester)
- Drilling machine and bits suitable for the surface on which the SMI will be installed
- Suitable screws for attaching the mounting bracket to the surface to which it will be connected
- Wire cutters
- Wire strippers
- Voltmeter
- DC current clamp-on meter
- Three-wire 4mm² (12AWG) max AC cable with a diameter of 10–14 mm (0.4"–0.55")

For installing the communication options, you may also need the following:

- For Ethernet: CAT5/6 twisted pair Ethernet cable
- For RS485: Four- or six-wire twisted pair

Chapter 2: Installing the Safety and Monitoring Interface

This chapter describes how to mount the SMI device using its mounting bracket. At this stage, power optimizers are already installed and connected in strings. For more information on power optimizers' installation, refer to the manuals available on the SolarEdge website at <http://www.solaredge.com/groups/support/downloads>.

SMI Transport and Storage

Transport the SMI device in its original packaging, facing up and without exposing it to unnecessary shocks. If the original package is no longer available, use a similar box, which can withstand the SMI weight (3 kg) and can be closed fully.

Store the SMI in a dry place where ambient temperatures are -40°C to $+60^{\circ}\text{C}$ / -40°F to 140°F .

SMI Package Contents

- One SMI device
- One mounting bracket
- Four flat head screws and eight washers for fastening the SMI to the mounting bracket
- One AC cable connector with a sealing/assembly cap
- One universal unlocking tool for PV module connectors
- This Installation Guide

Identifying the SMI

Refer to the sticker on the SMI that specifies its **Serial Number** and its **Electrical Ratings**. Provide the serial number when contacting SolarEdge support. The serial number is also required when opening a new site in the SolarEdge monitoring portal.

Mounting the SMI



CAUTION:

Do not rest the connectors at the bottom of the SMI on the ground, as it may damage them. To rest the SMI on the ground, lay it on its back, front or side.

- 1 Determine the SMI mounting location, on a wall or pole, as follows:
 - To allow for heat dissipation, maintain an 8" (20 cm) clearance between the top of the SMI and other objects.
 - Position the mounting bracket against a wall or pole and mark the drilling hole locations:
 - Ensure that the semi-circles are facing down, as shown below.

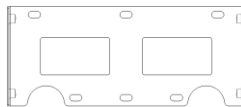

Figure 2: SMI Mounting Bracket

- Use at least two bracket holes. Additional holes can be used to fix the bracket. Determine which and how many holes to use according to mounting surface type and material.
- 2 Drill the holes and connect the bracket. Verify that the bracket is firmly attached to the mounting surface.
 - 3 Attach the SMI to the bracket using the four supplied screws. Tighten the screws with a torque of 9 N*m / 6.6 lb*ft.

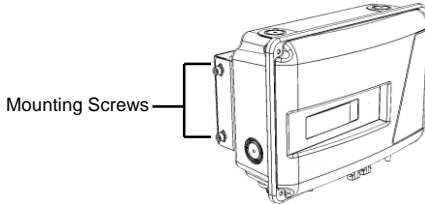

Figure 3: Attaching the SMI to its Mounting Bracket

SMI Connectors

The following describes the SolarEdge SMI connectors, ON/OFF switch and LCD light button:

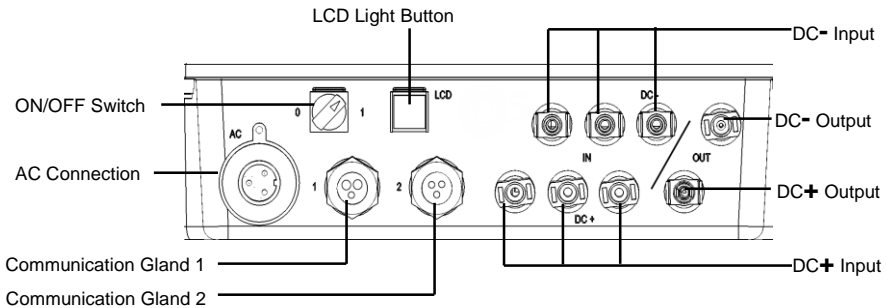

Figure 4: SolarEdge SMI Connectors

- **ON/OFF Switch:** Turning this switch ON (1) starts the operation of the power optimizers. Turning it OFF (0), reduces the power optimizer voltage to a low safety voltage.
- **LCD Light Button:** Pressing this button lights up the LCD for 30 seconds. In addition, you can press this button to access configuration menu options, as described in *Configuring the SMI Using the LCD Light Button* on page 19.
- **Two Communication Glands**, each 20mm in diameter, for connection of inverter communication options. Each gland has three openings. Refer to *Chapter 7: Setting Up Communication* on page 33.
- **AC Connector:** Used to wire AC to the SMI
- **DC Inputs:** Used to connect the modules strings to the SMI
- **DC Outputs:** Used to connect the SMI to the inverter

Connecting the SMI to AC

The AC is connected using a special IP68-rated connector supplied with the SMI.

Use any three-wire 4mm² (12 AWG) max AC cable with a diameter of 10–14 mm (0.4–0.55").

► To wire the AC connector:

- 1 Use the sealing cap to unscrew the locking ring of the AC connector and remove the socket insert.



Figure 5: AC Connector and Sealing Cap

- 2 Strip off the AC cable insulation and expose three wires (two line wires and one grounding wire).
- 3 Thread the cable through the connector parts, as shown below.

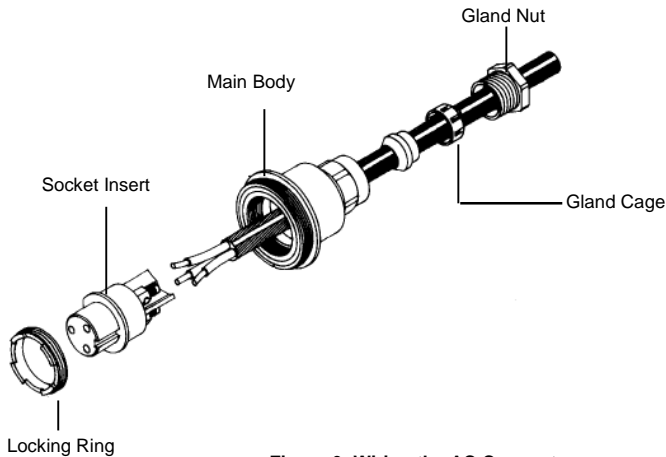

Figure 6: Wiring the AC Connector

- 4 Insert the wire ends into the terminals on the socket insert. Make sure to wire according to the local regulations.

- 5 Tighten the screws.

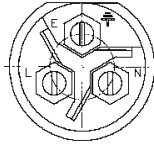

Figure 7: AC Connector Screws

- 6 Pull the cable back until the socket insert is correctly positioned in the D-shaped opening of the main body.
- 7 Screw the locking ring into place.

▶ **To connect the SMI to AC:**



CAUTION:

The AC circuit breaker rating should not exceed 16A.

- 1 Turn OFF the AC circuit breaker (if applicable) connected to the SMI.
- 2 Turn OFF the ON/OFF switch at the bottom of the SMI.
- 3 Connect the cable to the SMI AC connector and close tightly
- 4 Turn ON the AC circuit breaker connected to the SMI.

Chapter 3: Connecting PV Strings to the Safety and Monitoring Interface

Overview

The following procedure describes how to connect the DC cables from the power optimizer strings to the SMI.

The following example shows a connection of two strings to the SMI.

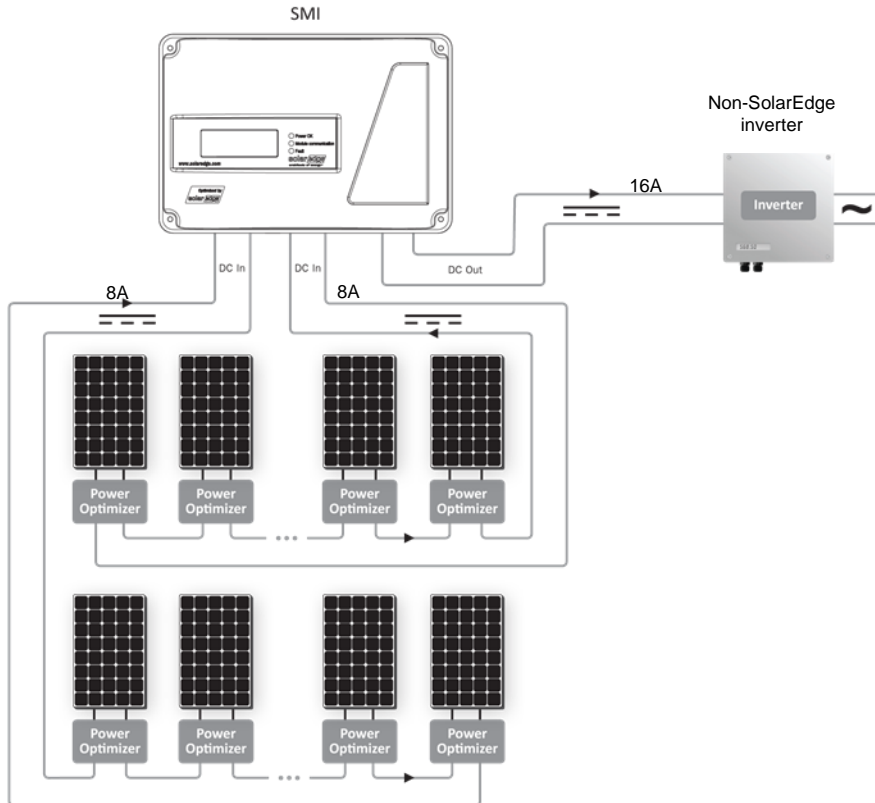

Figure 8: Example - 2 x Strings Connection, Ungrounded Array

The following example demonstrates a connection of four strings to the SMI through a fused combiner box, with proper and improper grounding locations (marked ✓ and ✗).

NOTE: When connecting the SMI to a grounded array, the grounding must not be between the SMI and optimizers. All grounding should be at the inverter or between the SMI output and the inverter. The SMI allows either positive or negative grounding.

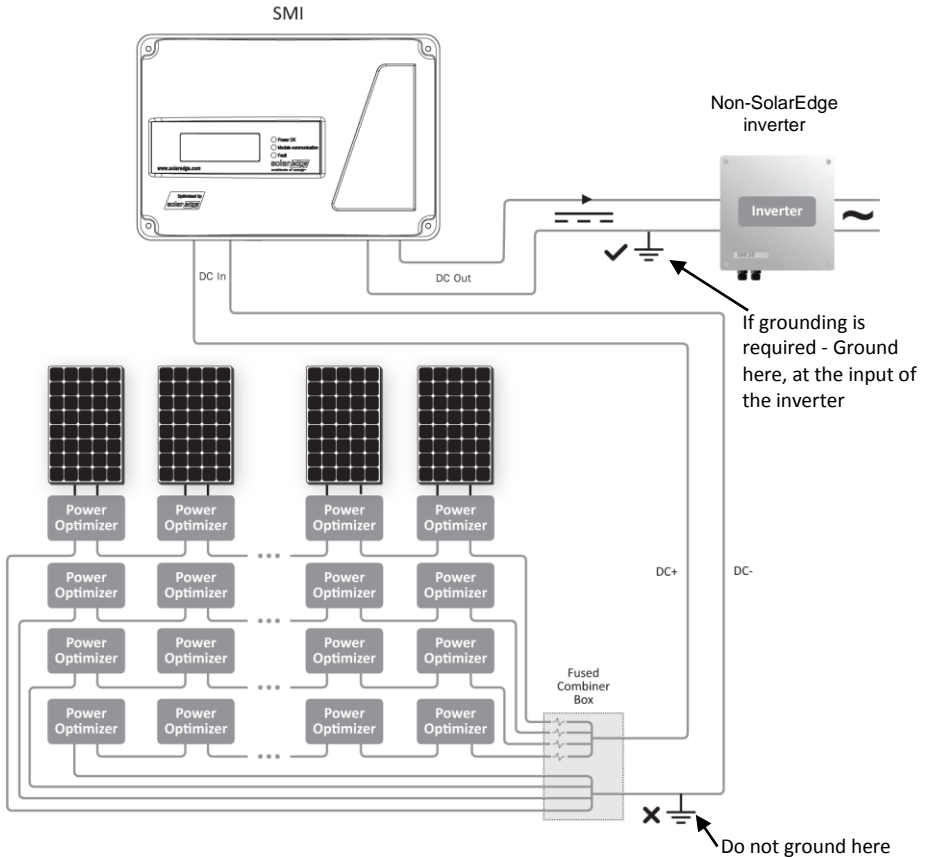

Figure 9: Example - Grounded Inverter, 4 x Strings Connection, Fused (Optional) Combiner Box



CAUTION: Only one SMI may be installed for each inverter. If the inverter has multiple MPPT trackers, one SMI may be installed for each MPPT input.

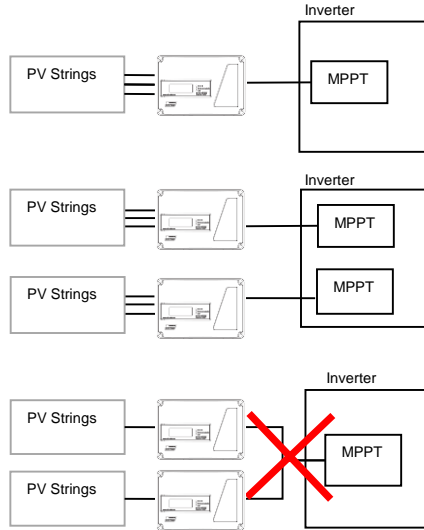

Figure 10: SMI-Inverter Connections

► **To determine how many strings can be connected to the SMI:**

- Verify that the cumulative short circuit current (I_{sc}) of all parallel-connected strings is below:
 - The rated maximum input current of the inverter
 - The rated maximum input current of the SMI

► **To connect DC strings to the SMI:**

- Connect the DC strings from the photovoltaic strings of optimizers to the **DC+** and **DC-** input connectors as indicated. The DC inputs are wired together inside the SMI.
- The SMI has three DC inputs. You can connect more than three strings to the SMI using an external combiner box or branch cables.

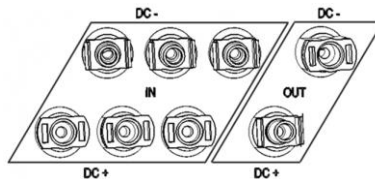

Figure 11: DC Input and Output Connectors



NOTE: For proper operation, make sure that no string diodes are connected in series between the strings and the SMI.

Chapter 4: SMI User Interface

External Interface - LCD, LEDs and LCD Light Button

The front of the SMI has an LCD panel and three LEDs, as shown below:

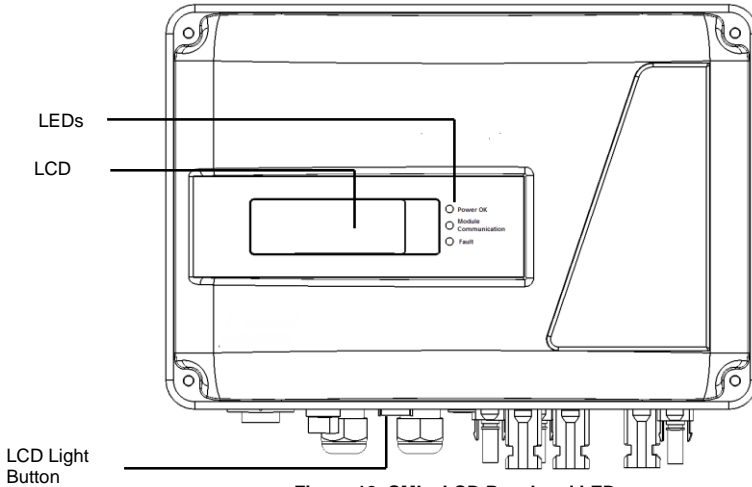

Figure 12: SMI – LCD Panel and LEDs

The LCD panel has three LED indicators:

- **Power OK - Green:** Indicates whether the SMI is connected to AC power.
- **Module Communication - Yellow:** This LED blinks when monitoring information is received from a power optimizer.
- **Fault - Red:** Indicates that there is an error. Refer to *Appendix A: Errors and Troubleshooting* on page 46 for more information. In addition, this LED blinks while the SMI is being shut down.

All LEDs are on while the SMI is being configured.

The **LCD Light Button** is located at the bottom panel of the SMI. Pressing this button lights up the LCD for 30 seconds. In addition, you can press this button to access configuration menu options, as described in *Configuring the SMI Using the LCD Light Button* on page 19.

Internal Interface - The LCD User Buttons

Four buttons are located at the top of the LCD panel inside the SMI and are used for controlling the LCD menus, as shown below:

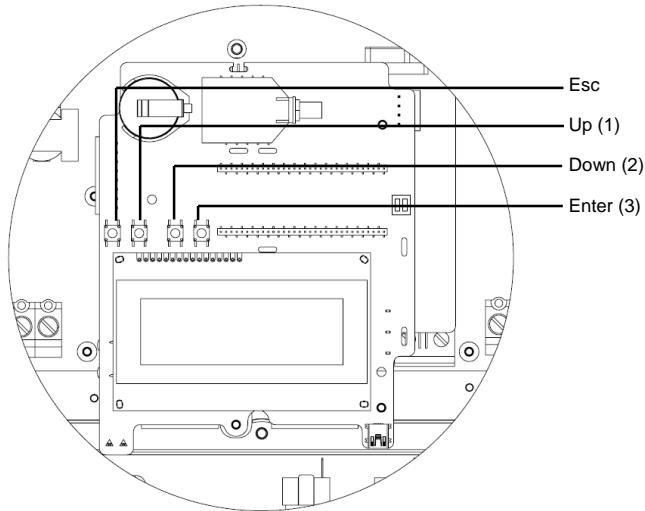

Figure 13: LCD Internal Menu Buttons

- **Esc:** Moves the cursor to the beginning of the currently displayed parameter; goes to the previous menu, and cancels a value change with a long press (until **Aborted** is displayed).
- **Up (1), Down (2):** Moves the cursor from one menu option to another, moves among the characters of a displayed parameter, and toggles between possible characters when setting a value.
- **Enter (3):** Selects a menu option and accepts a value change with a long press (until **Applied** is displayed).

Use the three rightmost buttons for entering 123 when entering the password.

The LCD panel and buttons may be used during the following:

- **Setup:** After inverter installation, the field technician may perform basic inverter configuration, as described in *Configuring the SMI Using the LCD User Buttons* on page 18.
- **Operational Mode:** The LCD panel enables checking that the inverter is working properly. Refer to *Operational Mode – Status Screens* on page 24 for a description of this option. Use the LCD light button to toggle through the informative displays.
- **Error messages:** In the event of a problem, an error message may be displayed on the LCD panel. Refer to *Appendix A: Errors and Troubleshooting* on page 46 and to *Configuring the SMI Using the LCD User Buttons* on page 18 for more information.

Setup

The SMI can be configured in one of two ways:

- **Configuring the SMI Using the LCD User Buttons**, page 18. When using this option, the SMI cover is removed.
- **Configuring the SMI Using the LCD Light Button**, page 19. When using this option, removing the SMI cover is not required.

Configuring the SMI Using the LCD User Buttons

- 1 Turn OFF the DC from the inverter, either by turning off the DC breaker (if applicable) or by turning OFF the inverter as described in its manual.
- 2 Turn the SMI ON/OFF switch to OFF.



WARNING!

If the SMI was operating properly (power was produced by the power optimizers), the following message is displayed.

```
D C V O L T A G E   N O T
S A F E
D O   N O T
D I S C O N N E C T
      V D C :
7 2 . 0
```

This message is displayed until the DC voltage is safe (50V). Do not open the cover until the voltage is safe or until at least five minutes have passed.



WARNING!

Do not touch the DC power connections until the DC voltage is at a safe level. Doing so may cause injury or loss of life, damage to the device and/or danger of fire.

- 3 Open the SMI cover, as described in *Appendix D: Opening and Closing the SMI Cover* on page 51.
- 4 Press the Enter button for at least 5 seconds. The following message is displayed:

```
P l e a s e   e n t e r
P a s s w o r d
* * * * *
```

- 5 Use the three rightmost internal LCD user buttons to type in the following password: **12312312**. The following message is displayed:

```
L a n g u a g e   < e n g >
C o m m u n i c a t i o n
D i s p l a y
M a i n t e n a n c e
I n f o r m a t i o n
```

The SMI is now in Setup mode and all its LEDs are lit. The SMI automatically exits Setup mode if no buttons are pressed for more than 2 minutes.

The following shows a hierarchical tree of the menu options, which are described in *SMI Configuration Menu Options* on page 21

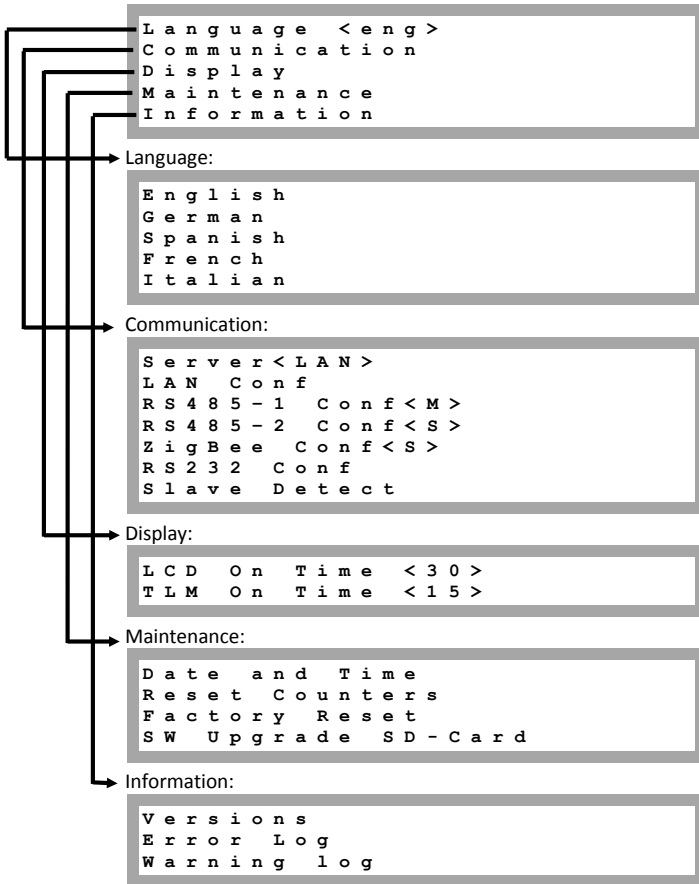

Each menu option is described in *SMI Configuration Menu Options* on page 21.

Configuring the SMI Using the LCD Light Button

The LCD light button can be used for communication setup and displaying the Error log and Warning Log without having to open the SMI cover. There are fewer menus available when using this configuration option; however, the functionality is the same as when using the LCD User buttons.

- 1 Press and hold down the LCD light button until the following message is displayed:

```
Keep holding button
for pairing, release
to enter menu...
Remaining 3sec
```

Releasing the button displays the following menu:

```
Optimizer pairing
Language <eng>
Communication
Information
Maintenance
Exit
```

- 2 Short press to scroll down to the next menu option and a long press to select the item. You can use the **Exit** options in these menus to move up one menu level or to exit the Setup mode from the main menu.

The following shows a hierarchical tree of the menu options that appear when using the LCD light button:

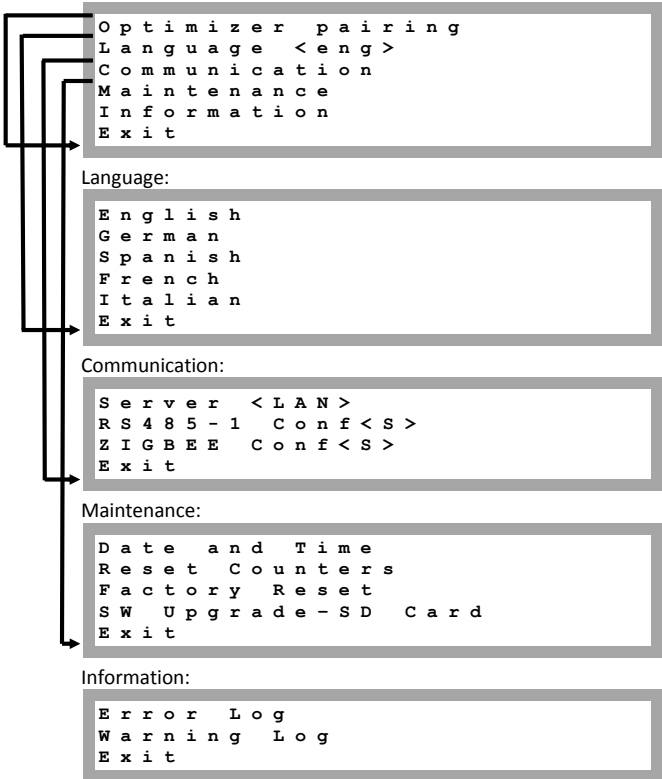

The options presented in these menus are described below.

SMI Configuration Menu Options

This section describes how to use the LCD menus for configuring the SMI. Use either the internal LCD user buttons or the external LCD light button to move between and select menu options.

Language

Select the **Language** option to set the language in which the LCD should display.

Communication

- 1 Select the **Communication** option to define and configure the communication option used by the SMI to communicate with the SolarEdge Monitoring Server and the communication option used to communicate between multiple inverters.
- 2 Select **Server** to set which communication method is used to communicate between the SMI and the SolarEdge Monitoring Server. Refer to *Chapter 7: Setting Up Communication* on page 33 for a full description of these communication options.

**NOTE:**

This menu shows only the communication options installed in the inverter.

- 3 The following shows a hierarchical tree of the menu options in the **Communication** menu. For detailed information about all the configuration options refer to the *Communication Options Application Note*, available on the SolarEdge website at http://www.solaredge.com/files/pdfs/solaredge-communication_options_application_note_v2_250_and_above.pdf.

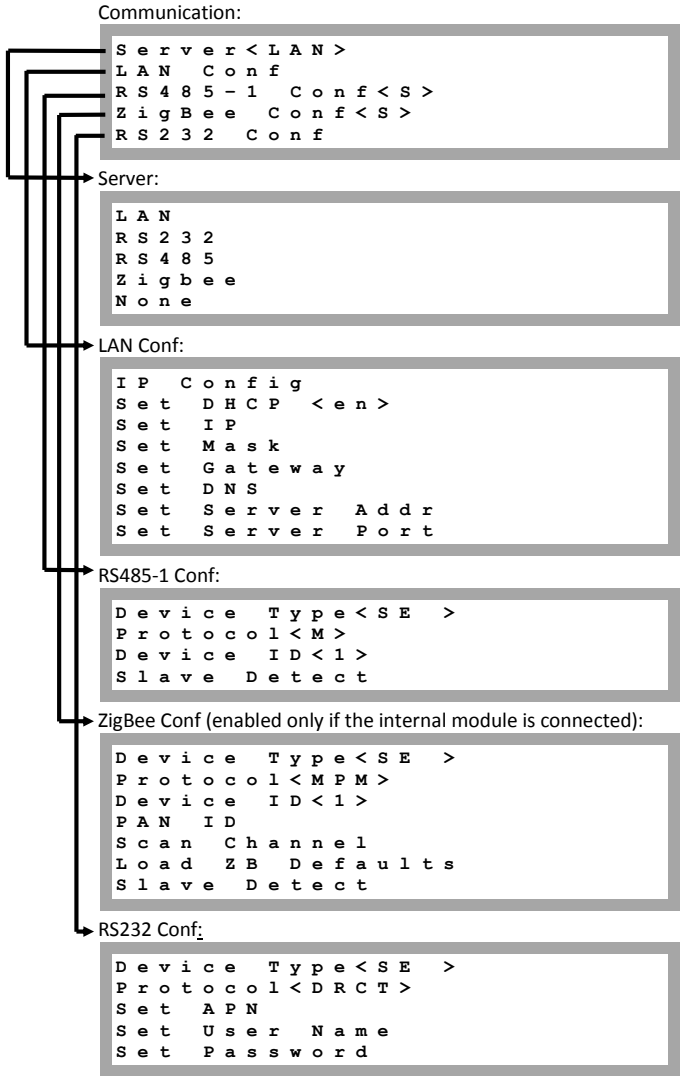

Display

Select **Display** to set the following three options:

```
T e m p e r a t u r e < C >
L C D   O n   T i m e < 3 0 >
T L M   O n   T i m e < 1 5 >
```

- **Temperature:** Select Celsius or Fahrenheit units.
- **LCD On Time <30>:** The number of seconds that the LCD backlight is ON after the LCD light button is pressed.
- **TLM On Time <15>:** The number of minutes that the LCD backlight is ON while viewing the *Telemetry* window.

Maintenance

Select **Maintenance** to set the following options:

```
D a t e   a n d   T i m e
R e s e t   C o u n t e r s
F a c t o r y   R e s e t
S W   U p g r a d e   S D   C a r d
```

- **Date and Time:** Set the internal real-time clock. If connected to the SolarEdge monitoring portal, the date and time are set automatically and only time zone should be set.
- **Reset Counters:** Reset the accumulated energy counters that are sent to the SolarEdge monitoring portal
- **Factory Reset:** Perform a general reset to the **SMI** default settings.
- **SW Upgrade SD Card:** Perform a software upgrade using an SD card.

Information

Select **Information** to display the following options:

```
V e r s i o n s
E r r o r   L o g
W a r n i n g   l o g
```

- **Versions:** Displays inverter firmware versions :

```
I D :   # # # # # # # # # #
D S P   V e r :   1 . 2 1 0 . 1 7 7
C P U   V e r :   2 . 2 9 3
```

- **ID:** The SMI ID
- **DSP ver.:** The motherboard firmware version
- **CPU ver.:** The communication board firmware version



NOTE:

Please have these numbers ready when you contact SolarEdge support.

- **Error Log:** Displays the last five errors.
- **Warning Log:** Displays the last five warnings.

Operational Mode – Status Screens

Pressing the external LCD light button or the internal Enter user button turns on the LCD backlight. Additional presses display the following screens one after the other.

Initial SMI Status

```
V d c [ V ]   I d c [ V ]   P d c [ W ]
1 4 . 1       - - . -       - - - - -
P _ O K :    x x x / y y y < S _ O K >
                O F F
```

- **Vdc [V]:** The DC output voltage
- **Vdc [V]:** The DC input voltage
- **Pdc [W]:** The DC output power
- **P_OK: XXX/YYY:** There is a connection to the power optimizers and at least one power optimizer is sending monitoring data. XXX is the number of power optimizers for which telemetries have been received in the last two hours. YYY is the number of paired power optimizers identified during the most recent pairing process. If XXX and YYY are not equal, there may be a pairing issue.
- **S_OK:** The connection to the SolarEdge Monitoring server is successful (should appear only if the SMI is connected to the server)
- **ON/OFF:** Indicates the position of the inverter ON/OFF switch

Telemetry

This window displays the last power optimizer telemetry received. The display changes as each power optimizer sends its telemetry.

In order to verify proper installation, the installer may view the Telemetry window for some time in order to observe the power optimizers report process.

```
M o d u l e : x x x x x x x x - x x
E n e r g y [ W h ] : 5 9 7 . 0
V d c _ O [ V ] : 5 9 . 5
V d c _ I [ V ] : 2 9 . 5
```

- **Module:** Power optimizer serial number
- **Energy:** power optimizer energy
- **Vdc_O:** Power optimizer output voltage
- **Vdc_I:** Power optimizer input voltage (module voltage)

ID Status

This window displays the SMI software version.

```
I D : # # # # # # # # # #
D S P : 1 . 0 2 1 0
C P U : 0 0 0 2 . 0 1 1 1
```

- **ID:** The SMI ID
- **DSP ver.:** The motherboard firmware version
- **CPU ver.:** The communication board firmware version

Server Communication Status

```

S e r v e r : L A N           < S _ O K >
S t a t u s : x x x x x x x x < O K >

< E R R O R   M E S S A G E >

```

- **Server:** The method of connection to the SolarEdge monitoring server
- **S_OK:** The connection to the SolarEdge monitoring server is successful (appears only if the inverter is connected to the server).
- **Status:** Displays OK if the inverter established a successful connection and communication with the specified server port/device (LAN, RS485, ZigBee module, or external GSM modem).
- **xxxxxxxx:** Eight-bit Ethernet Communication Connection Status: A string of 1s and 0s is displayed. 1 indicates OK, 0 indicates an error. Refer to *Troubleshooting Communication* on page 47.

IP Status

This window describes the Ethernet configuration: IP, Mask, Gateway and MAC address (Media Access Control) of the SMI.

```

I P      1 9 2 . 1 6 8 . 2 . 1 1 9
M S K    2 5 5 . 2 5 5 . 2 5 5 . 0
G W      1 9 2 . 1 6 8 . 2 . 1
M A C    0 - 2 7 - 0 2 - 0 0 - 3 9 - 3 6

```

ZigBee Status

This window describes the ZigBee configuration:

```

P A N : X X X X X
C h : X X / X X X X   R S S I : < L >
I D : X X X X X X X X
M I D : X X X X   X X

```

- **RSSI:** The receive signal strength of the closest ZigBee in the SolarEdge system. L = low, M = medium, H = high and - = no signal.
- **PAN ID:** The ZigBee module pan ID.
- **Ch.:** The ZigBee module channel.
- **ID:** The ZigBee module ID.
- **MID:** The ID of the coordinator (master) ZigBee module. This field is shown only in devices with router (slave) ZigBee modules. This field appears after a successful ZigBee association. If a ZigBee module is not connected, a *No ZigBee* message is displayed instead of the **MID** field.

Communication Ports Status Window

```

                D e v   P r o t   # #
R S 4 8 5 - 1 < S E > < S > < - - >
R S 4 8 5 - 2 < S E > < M > < - - >
Z i g B e e   < S E > < M P S > < - - >

```

- **Dev:** The type of device that was configured to a specific port (based on the port's functionality), as follows:
 - **SE:** SolarEdge device (default)
 - **MTR:** Revenue meter
 - **INV:** Non-SolarEdge inverter
 - **LGR:** Non-SolarEdge logger

- **Prot:** The protocol type to which the port is set:
 - For a SolarEdge device:
 - **S:** SolarEdge slave
 - **M:** SolarEdge master
 - **P2P:** ZigBee point-to-point
 - **MPM:** ZigBee multipoint master (for a ZigBee coordinator module)
 - **MPS:** ZigBee multipoint slave (for a ZigBee router module)
 - For a *revenue meter* reader, refer to the supported revenue meters page at <http://www.solaredge.com/articles/se-supported-devices>.
 - For a non-SolarEdge logger: **SS:** SunSpec
- **##:** The total number of slaves detected on the specific port

Chapter 5: Commissioning the Safety and Monitoring Interface

The following workflow describes how to activate the system, commission the installation and verify the proper functioning of the system.

Step 1, Activating the System

At this stage, the inverter is not connected and is powered OFF.

- 1 Make sure that the SMI is connected to the AC power. Verify that its ON/OFF switch is OFF.
- 2 If the site is installed with an external DC switch between the power optimizers and the SMI, then turn it ON.

A message similar to the following appears on the inverter LCD panel:

```
V d c [ V ]   I d c [ A ]   P d c [ W ]
1 5 . 1       0 . 0       0 . 0
P _ O K :    0 0 0 / 0 0 0   < S _ O K >
                O F F
```

- 3 Verify that the following information appears on the LCD panel:
 - **P_OK**: Appears only upon first telemetry reception from the power optimizers. Indicates connection to the power optimizers and at least one power optimizer is sending monitoring data. If P_OK does not appear, check the power optimizer, string and DC input connections.
 - **000/000**: Appears only upon first telemetry reception from the power optimizers. Indicates the number of power optimizers that have been paired to this inverter. At this stage, the number should be 000, since no power optimizers have been paired.
 - **Vdc [V]**: the DC input voltage of the longest string connected to the SMI. There should be a safety voltage of 1V for each power optimizer in the string.



NOTE:

A measurement error on the inverter LCD of ± 3 V is acceptable.

- **Idc [v]**: the DC output current. The value is **0.0** since the inverter is still not connected. If no measurement is available, the display is ----.
- **Pdc [w]**: the DC output power; the value is **0.0** since the inverter is still not connected. If no measurement is available, the display is ----.
- **OFF**: the inverter ON/OFF switch is in the OFF position.

If the LCD panel shows 0V:

- Verify that the PV modules are not shaded or otherwise obstructed.
- Check for proper power optimizer, string and DC input connection.
- Verify the correct polarity of the DC input connection.

Step 2, Pairing Power Optimizers to the SMI

Once all connections are made, all the power optimizers must be logically paired to the SMI. The power optimizers do not start producing power until they are paired with an SMI. Perform this step when the modules are exposed to sunlight. If you add a power optimizer, re-pairing is required.

This step describes how to perform this pairing.



CAUTION:
Make sure that the output DC wire between the SMI and the inverter is disconnected.



CAUTION:
Complete the pairing procedure before connecting the DC output of the SMI to the inverter.

- 1 Verify that the SMI ON/OFF switch is OFF.
- 2 Press and hold down the SMI's LCD Light button for about **10 seconds**. The following message is displayed:

```
Keep holding button  
for pairing, release  
to enter menu...  
Remaining: 3 sec
```

Keep holding for 5 seconds until the following is displayed:

```
Pairing  
Turn Switch To On
```

- 3 Turn the SMI ON **within five seconds**. If you wait longer than 5 seconds, the SMI exits pairing mode. The following message is displayed indicating that the inverter is performing the pairing.

```
Pairing  
Remaining [sec]: 180
```

- 4 Wait for the completion of the pairing (remaining seconds is 0). If pairing fails, an error is displayed. In this case, repeat the pairing steps. When pairing succeeds, the following message is displayed:

```
Pairing  
Pairing Completed
```

- 5 The system startup process begins: Since the SMI is ON, the power optimizers start producing power.



WARNING!
After you turn ON the SMI ON/OFF switch, the DC cables carry a high voltage and the power optimizers no longer output a safe 1V output.

Step 3, Verifying Proper Operation

After pairing, a message similar to the following appears on the inverter LCD panel:

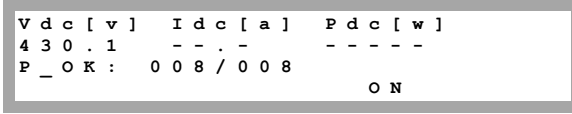

1 Verify the following:

- The green **SMI** LED is steadily lit.
- The ON/OFF indicator on the LCD panel reads **ON**.
- **P_OK: XXX/YYY**: There is a connection to the power optimizers and at least one power optimizer is sending monitoring data. Optimizers send telemetries every 10 minutes approximately. Initially after pairing, the YYY number shows the number of paired power optimizers, and XXX shows 000 since no optimizer reported in the last hour. While telemetries arrive from different optimizers, the XXX value increases until reaching the number of paired optimizers. This should take approx. 20 min. If XXX and YYY are not equal after 20 minutes, there may be a pairing issue.



NOTE:

It can take up to 20 minutes for all power optimizers to transmit their telemetries and to be counted on the LCD screen.

- **Vdc [v]** specifies the DC input voltage, which should equal the output voltage of all panels (and within the operating range of the inverter).

2 Take note of the serial # on the SMI label. This information is used in the SolarEdge monitoring portal to identify this SMI and is needed to open a new site in the monitoring portal.

Step 4, Reporting and Monitoring Installation Data

The SolarEdge Monitoring System

The SolarEdge monitoring portal enables accessing site information, including up-to-date information viewed in a physical or logical view.

The Monitoring portal is described in detail in the *SolarEdge Monitoring Portal User Guide*, available on the SolarEdge website at <http://www.solaredge.com/files/pdfs/solaredge-monitoring-portal-user-guide.pdf>.

The SolarEdge monitoring portal can display logical and physical layouts of the installed system, as follows:

- **Logical Layout:** Shows a schematic logical layout of the components in the system, such as: inverters, clusters, strings and modules, as well as their electrical connectivity. This view enables you to see which modules are connected in each string, which strings are connected to each inverter, and so on.
- **Physical Layout:** Shows a schematic physical layout of the components in the system, such as: inverters, clusters, strings and modules, as well as their electrical connectivity. This view enables a **bird's eye view** of the actual location of a system component.

Using the portal, you can:

- View the latest performance of specific components.
- Find underperforming components, such as modules, by comparing their performance to that of other components of the same type.

- Pinpoint the location of alerted components using the physical layout.
- See how components are connected to each other.

To display a logical layout, the serial numbers and other general information are required.

To display a physical layout, you need to map the locations of the installed power optimizers. To generate a physical mapping, use either the iPhone Site Mapper application or a mapping template, which should be filled out using the detachable stickers (see *Providing Installation Information* on page 30).

The logical and physical mapping can be used for debugging a problem using the SolarEdge monitoring portal.

If you do not report the physical and logical mapping of the installed power optimizers to SolarEdge, the SolarEdge monitoring portal will show the logical layout indicating which power optimizers are connected to which inverters, but will not show strings or the physical location of power optimizers.

You can connect the SMI to the SolarEdge Monitoring Server via LAN or via an external modem connected to the RS232 connector. Alternatively, you can connect the SMI to another SMI that is already connected to the server, in a master-slave configuration. Refer to *Chapter 7: Setting Up Communication* on page 33.

Providing Installation Information

Paper Template

Fill out the Physical Layout Template using the detachable 2D barcode stickers on each power optimizer. Once the form is completed, scan it and upload the scanned file to the SolarEdge monitoring portal during site registration. For an example paper template, refer to <http://www.solaredge.com/files/pdfs/physical-layout-template.pdf>.

For detailed information, refer to the *SolarEdge Site Mapping Template Application Note*, available on the SolarEdge website at http://www.solaredge.com/files/pdfs/application_note_using_site_mapping_template.pdf.

iPhone Site Mapper

Use the SolarEdge Site Mapper iPhone application to scan the power optimizer and SMI 2D barcodes. It then creates a file that can be uploaded to the SolarEdge monitoring portal during site registration. The SolarEdge Site Mapper can be downloaded from the Apple iTunes Store.

For detailed information, refer to the *SolarEdge Site Mapper Software Guide* or to the *Site Mapper demo movie*, available on the SolarEdge website at <http://www.solaredge.com/groups/installer-tools/site-mapper>.

Creating a Site in the SolarEdge monitoring portal

Create the site in the monitoring portal using the registration form available at the following link: <http://www.solaredge.com/groups/site-registration>. Fill out all required information in the form, which includes information about your installation, as well as details about its logical and physical mapping.

Chapter 6: Connecting the Inverter

Only one SMI may be installed for each inverter. If the inverter has multiple MPP trackers, one SMI may be installed for each MPPT input. Refer to Figure 10 on page 15 for examples of correct and incorrect connections.

Step 1, Connecting the inverter to the SMI

- 1 Turn OFF the SMI ON/OFF switch and the DC breaker between the SMI and modules (if applicable). The SMI enters the SafeDC mode and displays the following message. This message is displayed until the DC voltage is safe (50V).

```

D C   V O L T A G E   N O T   S A F E
D O   N O T   D I S C O N N E C T
V D C :           7 2 . 0
  
```



WARNING!

Do not touch the DC power connections until the voltage is safe or until at least five minutes have passed.

- 2 Switch the AC to the inverter OFF (as described in its manual). If applicable, turn the inverter AC/DC Safety Switch to OFF.
- 3 Verify that the pairing procedure is complete, as described *Step 2, Pairing Power Optimizers to the SMI* on page 28.
- 4 Connect the SMI **DC+** and **DC-** output circuits to the input of the inverter.



CAUTION:

Only one SMI may be installed for each inverter. If the inverter has multiple MPP trackers, one SMI may be installed for each MPPT input.



CAUTION:

Complete the pairing procedure *before* connecting the DC output of the SMI to the inverter. Do not perform pairing when the DC output of the SMI is connected to the inverter.

- 5 Switch the AC to the inverter ON (as described in its manual). If applicable, turn the inverter AC/DC Safety Switch to ON.
- 6 Turn ON the SMI ON/OFF switch and the DC breaker in the main distribution panel (if applicable).
- 7 Wait for the inverter to start producing power.

Step 2, Verifying Proper Operation

A message similar to the following appears on the LCD panel:

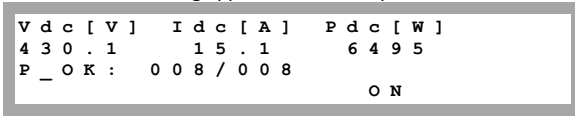

- 1 Verify the following:
 - The green inverter LED is steadily lit.
 - The ON/OFF indicator on the LCD panel reads **ON**.
 - **P_OK: XXX/YYY**: There is a connection to the power optimizers and at least one power optimizer is sending monitoring data. **Vdc [v]** specifies the DC input voltage, which should be within the DC voltage operating range of the inverter.
 - **Pdc [w]** specifies the expected DC output power.
- 2 Take note of the serial # on the inverter label. This information is used in the SolarEdge monitoring portal to identify this inverter and is needed to open a new site in the monitoring portal.

Your power harvesting system is now operational.

Chapter 7: Setting Up Communication

Communication Dataflow

Power optimizers send information to the SMI via DC lines (the PV output circuit). The SMI can send this information to the SolarEdge monitoring portal through the Internet.

Site information can be accessed remotely using the SolarEdge monitoring portal, as described in the *SolarEdge Monitoring Portal User Guide*. In order to send the data from the site to the SolarEdge monitoring portal, a communication connection must be set up, as described in this chapter.

Communication setup is not required for power harvesting and is needed only for using the monitoring portal.

This chapter also describes setting up communication between multiple SMI for a master/slave configuration.



CAUTION:

Only one SMI may be installed for each inverter. If the inverter has multiple MPP trackers, one SMI may be installed for each MPPT input.

Communication Types

- **Ethernet:** Used for a LAN connection
- **RS485:** Enables connection to multiple SolarEdge devices on the same bus in a master-slave configuration. RS485 type can also be used as an interface to external non-SolarEdge devices, such as revenue meters and data loggers. The SMI has two RS485 physical ports with the following capabilities:
 - **RS485-1:** Enables the connection of multiple SMIs through the same bus, such that connecting only one SMI to the Internet is sufficient to provide communication services for all the SMIs on the bus.
 - **RS485-2:** Enables connection of non-SolarEdge devices, such as inverters and revenue metering devices.
- **ZigBee (optional):** Enables wireless connection of one or more SolarEdge devices through a ZigBee transceiver.
- **RS232 (UART):** Used to connect to an external SolarEdge GSM modem that has an RS232 port.
- **Mini-USB:** Enables PC/laptop connection for software upgrade using the SolarEdge configuration tool. Use a USB to mini-USB cable for this connection.

Always connect the communication options when the SMI is OFF.

Communication Connectors

Two communication glands, each 20mm in diameter, are used for connection of the various SMI communication options. Each gland has three openings. The table below describes the functionality of each opening. Unused openings should remain sealed.

Gland#	Opening	Functionality	Cable Size (diameter)
1	One small	RS232	2-4 mm
	Two large	Ethernet connection (CAT5/6) or ZigBee	4.5-7 mm
2	All three	RS485, power reduction	2.5-5 mm

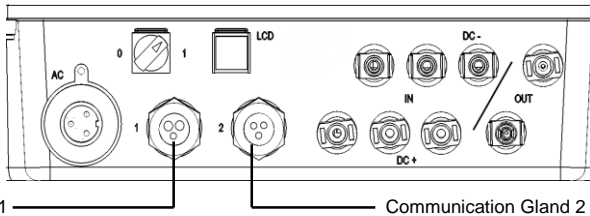

Communication Gland 1

Communication Gland 2

Figure 14: Communication Glands

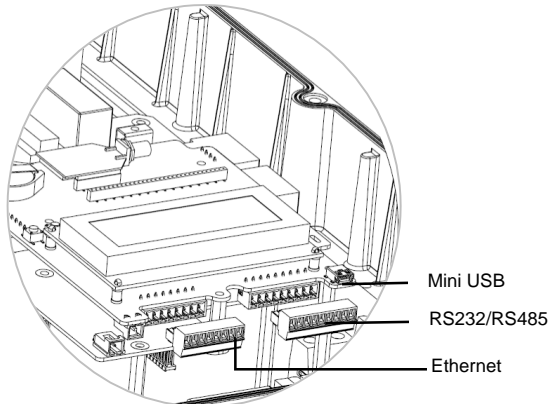

Figure 15: Internal Connectors

Creating an Ethernet (LAN) Connection

Overview

This communication option enables using an Ethernet connection to connect the SMI through a LAN network to the monitoring portal.

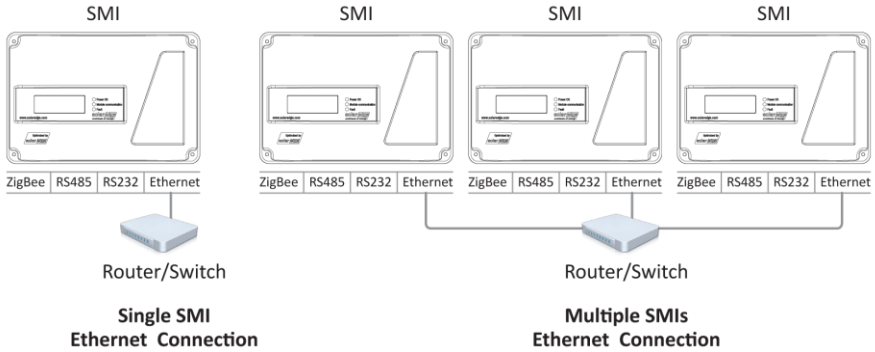

Figure 16: Example of Ethernet Connection

Ethernet Communication Configuration Options

The following is a description of the options to configure the Ethernet (LAN) port settings.

```

Communication
Server < LAN >
LAN Conf
RS485 - 1 Conf < S >
RS485 - 2 Conf < >
ZigBee Conf < >
RS232 Conf

LAN Conf
IP Config
Set DHCP < en >
Set IP
Set Mask
Set Gateway
Set DNS
Set Server Addr
Set Server Port
    
```

- **IP Config:** Displays the current IP configuration of the SMI, as shown below. If DHCP is used, this screen reflects the parameters retrieved from the DHCP server. If manual settings are used, the screen shows the last manually input configurations.

```

IP      0 . 0 . 0 . 0
MASK   2 5 5 . 2 5 5 . 2 5 5 . 0
GW     1 9 2 . 1 6 8 . 0 . 1
DNS    0 . 0 . 0 . 0
    
```

- **Set DHCP <En>**: If the LAN connection between the SMI and the SolarEdge monitoring portal has a DHCP server, enable this option by setting it to **Enable** (default). If this option is enabled, then the DHCP server automatically configures the IP, Subnet Mask, Gateway and DNS. If not, set them manually.
- **Set IP**: Enables setting the IP of the SMI according to the LAN settings:
 - Use the **Up** and **Down** buttons to adjust the value of each IP address octet.
 - Press the **Enter** button to move to the next IP address octet.
 - Long press the **Enter** button (until **Applied** message appears) – apply the value
 - Long press the **Esc** button (until **Aborted** message appears) – erase all characters

```
S e t u p   I P
1 9 2 . 1 6 8 . 2 . 7
```

- **Set Mask**: Set the subnet mask of the SMI according to the LAN settings.
- **Set Gateway**: Set the gateway address of the SMI according to the LAN settings.
- **Set DNS**: Set the DNS of the SMI according to the LAN settings.
- **Set Server Addr**: Set the IP address of the SolarEdge monitoring portal. This option is predefined in the SMI to specify the SolarEdge monitoring portal IP address and does not normally need configuration.
- **Set Server Port**: Enables setting the port through which to connect to the SolarEdge monitoring portal. This option is predefined in the SMI to specify the SolarEdge monitoring portal IP port and normally does not need configuration.



NOTE:
If your LAN has a firewall, you must verify that the address and port configured in the **Set Server Addr** and the **Set Server Port** fields are not blocked.
You may need to configure it to enable the connection to the following address:
Destination Address: prod.solaredge.com
Port: 22222

Connecting and Configuring LAN

▶ **To connect the Ethernet communication to the SolarEdge monitoring portal:**

- 1 Open the SMI cover, as described in Appendix D: Opening and Closing the SMI Cover on page 51.
- 2 Open gland #1.
- 3 Remove the plastic seal from the large opening that has a cut in the rubber fitting and insert an Ethernet CAT5/6 cable through the opening.



CAUTION:
The internal side of the gland includes a rubber waterproof fitting, which should be used to ensure proper sealing.

CAT5/6 standard cables have eight wires (four twisted pairs), as shown in the diagram below. Wire colors may differ from one cable to another. You can use either wiring standard, as long as both sides of the cable have the same pin-out and color-coding.

RJ45 Pin #	Wire Color*		10Base-T Signal 100Base-TX Signal
	T568B	T568A	
1	White/Orange	White/Green	Transmit+
2	Orange	Green	Transmit-
3	White/Green	White/Orange	Receive+
4	Blue	Blue	Reserved
5	White/Blue	White/Blue	Reserved
6	Green	Orange	Received-
7	White/Brown	White/Brown	Reserved
8	Brown	Brown	Reserved

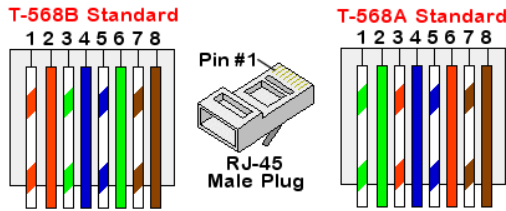

Figure 17: Standard cable wiring

4 Depending on the Ethernet connector type (RJ45 or an 8-pin terminal block), connect as follows:

- If the SMI has an 8-pin terminal block connector for Ethernet communication:
 - Pull the connector out, as shown below:

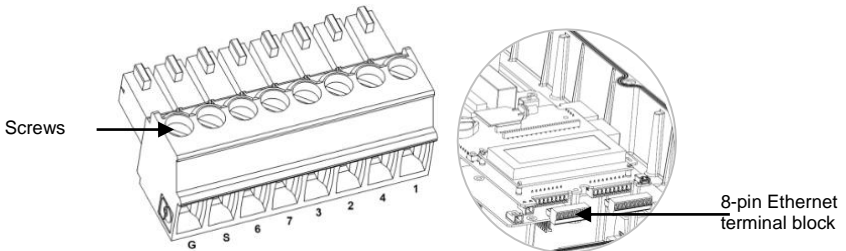

Figure 18: The 8-pin Ethernet terminal block

- Loosen the screws, except for that of pin G. Insert the ends of the wires into the pins according to the following table:

Terminal Block Pin #	RJ45 Pin #	Color	
		T568B Standard	T568A Standard
1	1	White/Orange	White/Green
2	2	Orange	Green

* The connection does not support RX/TX polarity change. Supporting crossover Ethernet cables depends on the switch capabilities.

Terminal Block Pin #	RJ45 Pin #	Color	
		T568B Standard	T568A Standard
3	3	White/Green	White/Orange
4	4 and 5	Blue + White/Blue	Blue + White/Blue
6	6	Green	Orange
7	7 and 8	Brown + White/Brown	Brown + White/Brown
S	Aluminum shield		
G-unconnected			

- Tighten the screws of the Ethernet terminal block.
 - Check that the wires are fully inserted and cannot be pulled out easily.
 - Push the Ethernet terminal block firmly all the way into the Ethernet connector on the communication board.
- If the SMI has an RJ45 connector for Ethernet communication, use a pre-terminated cable to connect via gland no.1 to the RJ45 plug on the SMI's communication board, or, if using a cable drum, connect as follows:
- Insert the cable through gland no.1.
 - Remove the cable's external insulation using a crimping tool or cable cutter and expose eight wires.
 - Insert the eight wires into an RJ45 connector, as described in Figure 17.
 - Use a crimping tool to crimp the connector.
 - Connect the Ethernet connector to the RJ45 plug on the communication board.

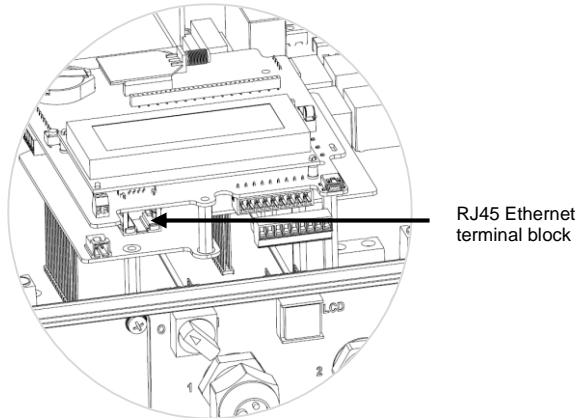

Figure 19: The RJ45 Ethernet connector

- 5** For the switch/router side, use a pre-terminated cable or use a crimper to prepare an RJ45 communication connector: Insert the eight wires into the RJ45 connector in the same order as in Figure 17.
- 6** Connect the cable's RJ45 connector to the RJ45 port of the Ethernet switch or router. You can connect more than one SMI to the same switch/router or to different switches/routers, as needed. Each SMI sends its monitored data independently to the SolarEdge monitoring portal.

- 7 SMIs are configured by default to **LAN**. If reconfiguration is required:
- Make sure the ON/OFF switch is OFF.
 - Turn ON the AC to the SMI by turning ON the circuit breaker on the main distribution panel.

**WARNING!**

ELECTRICAL SHOCK HAZARD. Do not touch uninsulated wires when the SMI cover is removed.

- Use the user buttons to configure the connection, as described in *Communication* on page 21.

**NOTE:**

If your network has a firewall, you may need to configure it to enable the connection to the following address:

- Destination Address: prod.solaredge.com
- TCP Port: 22222 (for incoming and outgoing data)

- 8 Verify the connection, as described in *Verifying the Connection* on page 45.

Interfacing with Other Devices Using an RS485 Bus

Overview

The SMI can connect to other SolarEdge devices, such as other SMIs, or SolarEdge control and communication gateways. The SMI can also connect to non-SolarEdge devices, such as revenue grade meters and non-SolarEdge inverter and read their data for display in the SolarEdge monitoring portal.

The RS485 option enables creating a bus of connected SMIs, consisting of one master SMI and up to 31 slave SMIs. Using this option, SMIs are connected to each other in a chain, via their RS485 connectors.

The RS485 bus uses a four-wire twisted-pairs cable connected to the RS485-1/2 terminal blocks located on the SMI communication board.

The following sections describe how to connect the RS485 bus and how to configure its components.

RS485 Configuration Options

In all configurations, use the following RS485 port configuration menus.

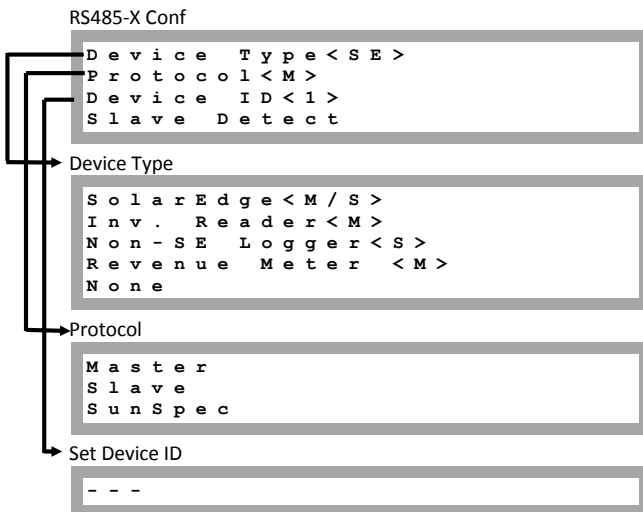

- **Device Type** is used to select the specific port configuration. The following devices are supported:
 - **SolarEdge** (default for RS485-1): Used when connecting to SolarEdge devices, such as: inverters, SMIs or other gateways. By default, all SolarEdge devices are pre-configured as slaves on the RS485-1 port.
 - **Inv. Reader**: Used for connecting to a non-SolarEdge inverter, in order to read its data and send it to the monitoring portal. For a list of supported Non-SolarEdge inverters, refer to <http://www.solaredge.com/articles/se-supported-devices>.
 - **Revenue Meter**: Used when connecting to an external revenue grade meter, in order to read the meter data and send it to the monitoring portal. For a list of supported meters, refer to <http://www.solaredge.com/articles/se-supported-devices>.
 - **Non-SE Logger**: Used when connecting to an external non-SolarEdge logger. The logger can read SolarEdge inverters data for Non-SolarEdge monitoring purposes.
 - **None** (default for RS485-2)
- **Protocol**:
 - When selecting a SolarEdge device, the following protocols appear under the Protocol option:
 - Slave (default)
 - Master
 - When selecting Device Type <Inv. Reader>, the Device Type <field> changes to Device Type <INV>
 - When selecting Device type <Non-SE Logger>, the Device Type <field> changes to Device Type <LGR> and the following protocol appears under the Protocol option: **SunSpec** (default)
 - When selecting Device type <Revenue Meter>, the Device Type <field> changes to Device Type <MTR>



NOTE:
For other supported protocols, refer to <http://www.solaredge.com/articles/se-supported-devices>.

- **Slave Detect**: Is used to initiate automatic detection of the slave SMIs connected to this master SMI. The number next to the option is the number of SMIs that have been detected.

Creating an RS485 Bus Connection

The first and the last devices in the chain must be terminated. Do not terminate devices along the bus. Use uses a four-wire twisted-pairs cable for the connection.

► To connect the RS485 communication bus:

- 1 Open the SMI cover, as described in Appendix D: Opening and Closing the SMI Cover on page 51.
- 2 Remove the seal from one of the openings in communication gland #2 and insert the wire through the opening.

- 3 Pull out the RS485/RS232 terminal block, as shown below:

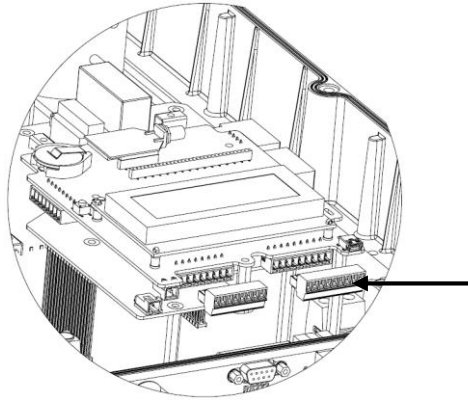

Figure 20: The RS485/RS232 Terminal Block

- 4 Loosen the screws of pins B, A and G on the left of the RS485-X block terminal.

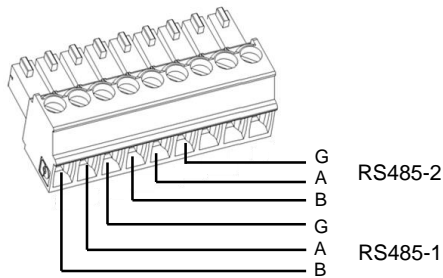

Figure 21: RS485/RS232 Block Terminal

- 5 Insert the wire ends into the G, A and B pins shown above. You can use any color wire for each of the A, B and G connections, as long as the same color wire is used for all A pins, the same color for all B pins and the same color for all G pins.
- 6 Connect all B, A and G pins in all SMIs. The following figure shows this connection schema:

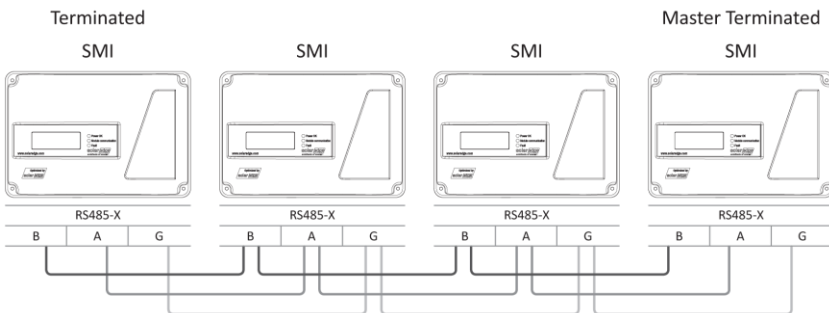

Figure 22: Example of Multiple SMIs in an RS485 Bus Connection



NOTE: Do not cross-connect **B**, **A** and **G** wires. Make sure you are using the same RS485-X port for all SMIs' connections.

- 7 Tighten the terminal block screws.
- 8 Push the RS485 terminal block firmly all the way into the communication board.
- 9 Terminate the first and last SMI in the chain by switching a termination dipswitch (located on the communication board and marked **SW7**) to ON (move the switch to the top).

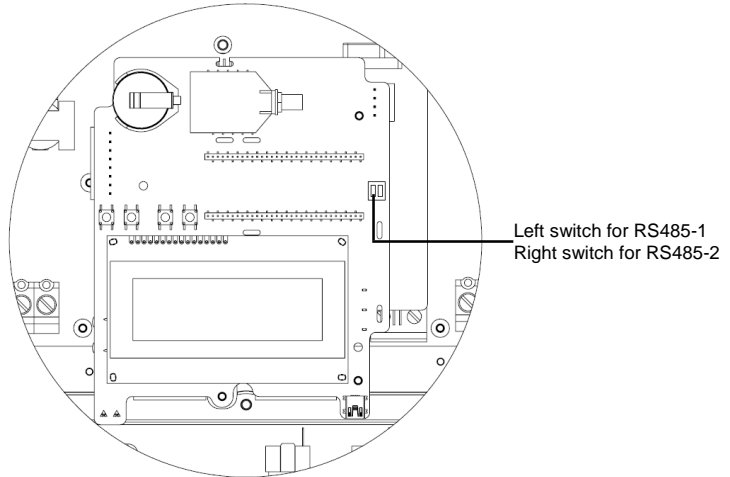

Figure 23: SMI RS485 Termination Switch



NOTE: Only the first and last SMI in the chain should be terminated. The other SMIs in the chain should have the termination switch OFF.

▶ To connect to the Server:

- 1 Designate a single SMI to be the connection point between the RS485 bus and the SolarEdge Monitoring Server. This SMI will serve as the master SMI.
- 2 Connect the master to the SolarEdge monitoring portal via one of the communication options (Ethernet or RS232).

▶ To configure the RS485 communication bus:

By default, all SolarEdge devices are pre-configured as slaves on the RS485-1 port. Slaves can be further configured using the **RS485-1 Conf** option in the Communication menu.

- 1 Enter Setup mode, as described in *Setup* on page 18.

- 2 Select **Communication** → **Server** → **RS485-X Conf** (X=1 or 2 depending on the specific physical port connection) to communicate with different external devices (SolarEdge inverters, revenue meters, non-SolarEdge loggers or non-SolarEdge inverters).
- 3 To configure the SMI designated as master, select the following in the LCD menus:
 - **Communication** → **RS485-1 Conf** → **Device Type** → **SolarEdge**
 - **RS485-1 Conf** → **Protocol** → **Master**
 - **RS485-1 Conf** → **Slave Detect**

The system starts automatic detection of the SolarEdge slave SMIs connected to the master SMI. The SMI should report the correct number of slaves. If it does not, verify the connections and terminations.
- 4 Verify the connection of the master to the SolarEdge Monitoring Server, as described in *Verifying the Connection* on page 44.

Connecting to Non-SolarEdge Inverters via RS485

A non-SolarEdge inverter can be connected to the SMI via RS485 for monitoring purposes. The SMI extracts information from the non-SolarEdge inverter and transfers it to the SolarEdge monitoring portal. Connection to the SolarEdge monitoring portal eliminates the need for an additional monitoring connection to the non-SolarEdge inverter, which may be provided by the inverter manufacturer, and provides all the monitoring benefits in one place.

A list of supported inverters is available on SolarEdge website at <http://www.solaredge.com/articles/se-supported-devices>.

Do not use the same bus for connecting multiple SMIs and for connecting to a non-SolarEdge inverter.

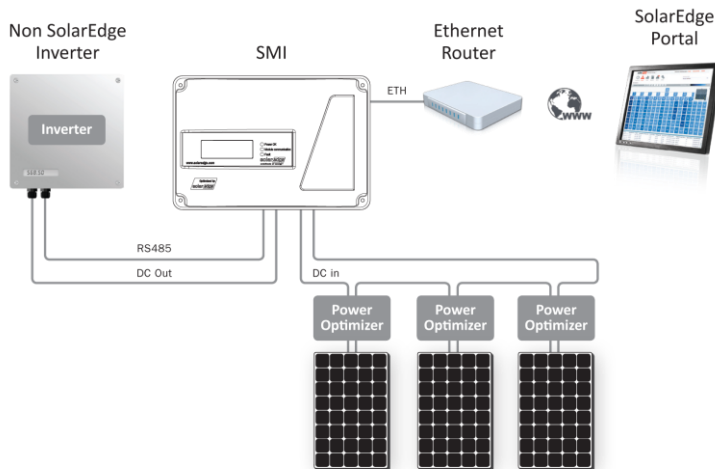

Figure 24: Example of SMI Connected to a Non-SolarEdge Inverter

► To connect the SMI to a non-SolarEdge inverter:

- 1 Connect the inverter using a standard twisted-pair cable to either of the two SMI RS485 connectors, as described above.
- 2 To configure the RS485 port to support the inverter and its specified protocol, select the following:
 - Communication → RS485-X
 - RS485-X → Device Type → Inverter Reader
 - RS485-X → Protocol and set the protocol to the preferred protocol.
- 3 Configure the SMI Ethernet port for the SolarEdge monitoring portal connection as described in *Ethernet Communication Configuration Options* on page 35.
- 4 Verify the connection to the SolarEdge Monitoring Server, as described in *Verifying the Connection* on page 44.

Additional Connection Options

Creating a Wireless ZigBee Connection

This communication option enables using a ZigBee connection for one of the following:

- To connect the SMI to the SolarEdge monitoring portal
- To create a master/slave bus of connected SMIs (up to 32)

The ZigBee device is provided with a user manual, which should be reviewed prior to connection. It is available on the SolarEdge website at

http://www.solaredge.us/files/pdfs/se_application_zigbee_communication.pdf and

http://www.solaredge.us/files/pdfs/se_application_zigbee_gateway.pdf.

Creating an RS232 (UART) Connection

RS232 enables connecting the SMI to an external SolarEdge GSM modem that has an RS232 output.

Refer to the *Cellular Modem Installation Guide for SolarEdge GSM Modem Connection and Configuration*.

This manual can be found on the SolarEdge website download section at:

http://www.solaredge.com/files/pdfs/se_application_gsm.pdf.

Connecting a Laptop to the SMI

To connect a laptop to the SMI, use the internal mini-USB connector (type B 5-pin) located on the communication board in the SMI (see Figure 15 on page 34). Use a USB to mini-USB cable.

Verifying the Connection

After each connection, perform the following to check that the connection to the monitoring server has been established successfully.

► To verify the connection:

- 1 Turn ON the AC to the SMI by turning on the circuit breakers on the main circuit board, and turn on the SMI.
- 2 Wait for the SMI to connect to the SolarEdge monitoring server. This may take up to two minutes. A message similar to the following appears on the LCD panel:

```

V d c [ v ]   I d c [ a ]   P d c [ w ]
 1 4 . 1     - - . -     - - - - -
P _ O K :    0 1 4 / 0 1 4   < S _ O K >
                   O F F
  
```

S_OK: Indicates that the connection to the SolarEdge monitoring server is successful.
If S_OK is not displayed, refer to Appendix A: Errors and Troubleshooting.

Appendix A: Errors and Troubleshooting

This appendix describes the error messages that appear on the SMI LCD panel when an error occurs, and how to troubleshoot them.

S_OK Not Displayed

If S_OK is not displayed, perform the following:

- Use a method independent of the SolarEdge SMI to check whether the network and modem are operating properly. For example, connect a laptop to the Ethernet router and connect to the Internet.
- Check with your network administrator whether a firewall or another device is blocking transmission.
- Check the configuration of the SMI.

Troubleshooting General Errors

The error messages include an error number and a description, and have the following format:

```

E r r o r   c o d e   x x x
x x x x x x x x x x x x x x x x x x x x
x x x x x x x x x x x x x x x x x x x x
    
```

An error message is displayed for 30 seconds, after which the SMI waits the necessary reconnection time and then restarts. During this time, the LCD displays the Waking Up message and the remaining time to reconnection.



WARNING!
All Warnings and Cautions in this manual should be adhered to while troubleshooting an error.

Error #	LCD Message	Description	Troubleshooting
15	DC Voltage Too High	DC overvoltage. The input DC voltage exceeds the maximum supported level.	The SolarEdge system normally eliminates DC overvoltage errors: When DC overvoltage is detected, the SMI shuts off the power optimizers and restarts. If the fault persists: <ul style="list-style-type: none"> ▪ Turn OFF the SMI ON/OFF switch. If after five minutes, the LCD panel does not show a low safety voltage (1V per optimizer), check which string is malfunctioning and recheck its connections to the SMI. ▪ Verify that no PV modules are connected directly to the SMI without a power optimizer. ▪ Re-commission all SMIs in the site, as described in <i>Chapter 5: Commissioning the Safety and Monitoring Interface</i> on page 16.
17	Temperature Too High	Over temperature.	If the problem persists: <ul style="list-style-type: none"> ▪ Verify that proper clearance exists around the SMI. ▪ Check whether the SMI is installed in an area that is too hot. ▪ Re-install in a cooler location.

Error #	LCD Message	Description	Troubleshooting
24	Faulty Temp. Sensor	Broken or unconnected temperature sensor.	If the problem persists, contact SolarEdge support.
27	Hardware Error	Internal hardware error.	If the problem persists, contact SolarEdge support.
43	Internal HW Error	Internal hardware error.	If the problem persists, contact SolarEdge support.
4, 5, 8, 12, 18-23, 39, 42, 45	SW Error	Internal software error.	If this fault persists, contact SolarEdge support.

Troubleshooting Communication

▶ To troubleshoot a communication problem:

- 1 Check that the modem or switch/router is functioning properly.
- 2 Check that the connection to the internal connector on the SMI communication board is properly done.
- 3 Check that the selected communication option is properly configured.
- 4 Check whether a firewall or another type of network filter is blocking communication.
- 5 Verify that the **Status** field in the *Server Communication Status* window displays OK. It indicates that the SMI has established a successful connection and communication with the specified server port/device (LAN, RS485, internal ZigBee module or external GSM modem).

If the status is not OK, a text message is displayed:

- For RS485 slave devices: **No Master Found:** The master device is not responding or the RS485 cable is not connected.
- For GSM modem and ZigBee module errors, refer to their relevant manual.

▶ To troubleshoot Ethernet communication:

When Ethernet communication is used, use the *Server Communication Status*, as described on page 25, to identify the location of the error.

```

Server : LAN          < S _ O K >
Status :              < O K >
          x x x x x x x x
< E r r o r M e s s a g e >

```

xxxxxxx is a string of 1s and 0s showing an eight-bit communication connection status. 1 indicates OK and 0 indicates an error. The possible errors and their troubleshooting are detailed in the following table:

Bit Location	Error Message	Error Description	Troubleshooting
1st	LAN Disconnected	An Ethernet physical cable connection fault: The Ethernet link or physical Ethernet cable are not connected properly	Check the cable pin-out assignment and cable connection
2nd	DHCP Failed, or	The SMI failed to get a valid IP address from the DHCP server, or	Check the router and SMI configuration

Bit Location	Error Message	Error Description	Troubleshooting
	Invalid DHCP Config	The DHCP/static IP settings in the gateway are not the same as those of the router.	
3rd	Gateway Ping Failed	The connection to the router is not available: Ping to the first hop switch/router failed (LAN error)	Check the physical connection to the switch/router. Check that the link LED at the router /switch is lit (indicating phy-link). If OK - contact your network IT, otherwise replace the cable or change it from cross to straight connection
4th	G Server Ping Failed	The connection to the Internet is not available: Ping to google.com failed	Connect a laptop and check for internet connection. If internet access is unavailable, contact your IT admin or your internet provider. For WIFI networks, ensure that username and password are as defined in the internet provider AP/router.
5th	Server x Ping Failed	Ping to redundant server #x failed	Check the SolarEdge server address in the <i>IP Status</i> , as described on page 25.
6th			
7th			
8th	Tcp Connect. Failed	The connection to the SolarEdge server was not established: Communication with the server failed	

Appendix B: Technical Specifications

General	
Model	SMI-35-3C-01
Safety Compliance	IEC-62109
Weight	3 kg / 6.6 lb.
DC Input / Output	
Maximum Voltage	1,000 VDC
Maximum Current	35 A
AC Input	
Input Voltage	90-264 VAC, 50/60 Hz
Maximum Continuous Input Current	300 mA
Physical Ratings	
Ambient Temperature	-20°C to +60°C
Enclosure Rating	IP65 / NEMA 4
Protective Class	Double insulation 

The SMI only operates with inverters that do not surpass the DC voltage and current limits of the SMI and that have been approved by SolarEdge. Refer to the SolarEdge website for a complete list of compatible inverters.

Appendix C: Mechanical Specifications

The following figure shows the mechanical specifications of the SMI in mm/[inch]:

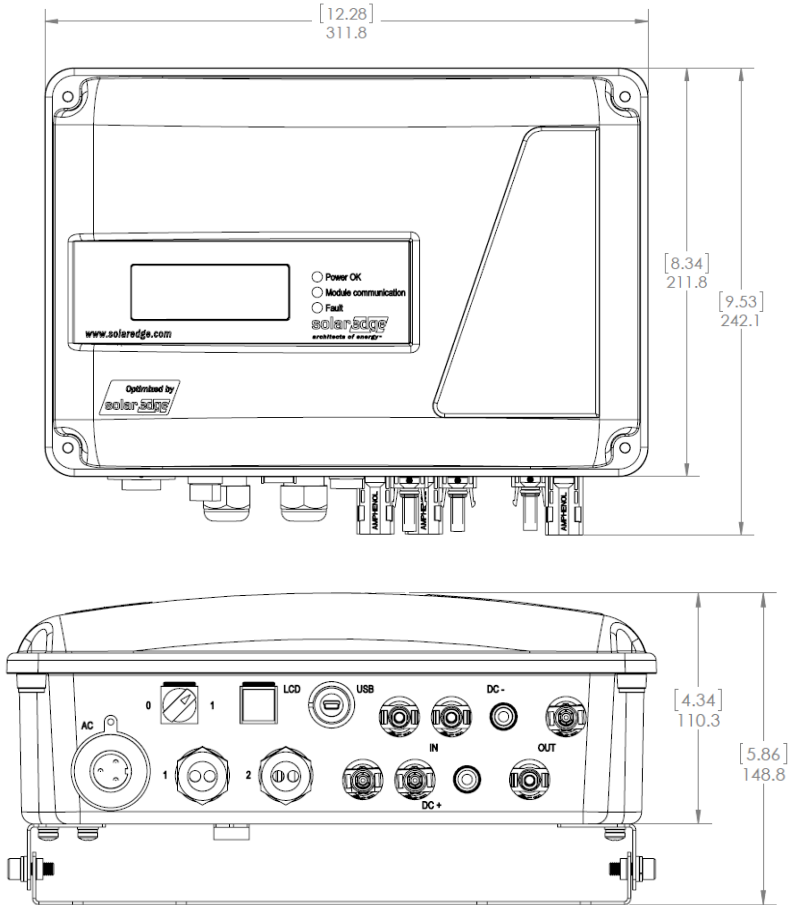

Figure 25: SolarEdge SMI Mechanical Dimensions

Appendix D: Opening and Closing the SMI Cover



CAUTION:

When removing the cover, make sure not to damage internal components. SolarEdge will not be held responsible for any components damaged as a result of incautious cover removal.

▶ To open the SMI cover:

- 1 Verify that the SMI is OFF.
- 2 Open the SMI cover's four Allen screws using an M6 Allen screwdriver and carefully lift the cover towards you before lowering it.

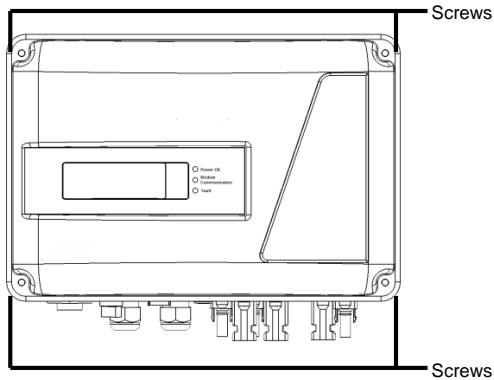

Figure 26: Opening the SMI Screws

▶ To Close the SMI cover:

- Close the SMI cover using the assembled four captive screws. Apply torque 3 N*m (26 Lb*in).. For proper sealing, first tighten two diagonally opposite screws and then the additional two screws. The recommended order is shown in the following figure:

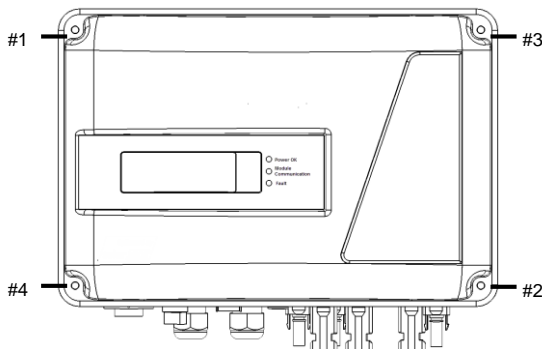

Figure 27: Tightening the Screws

If you have technical queries concerning our products, please contact our support through SolarEdge service portal:

<http://www.solaredge.com/groups/support/services>

North America	(Toll free) 1877 360 529 2
Australia	(Toll free) 1800 46 55 67
Germany	089 454 597 30
France	(Toll free) 0800 917 410
Italy	(Toll free) 800 784 824
Japan	(Toll free) +81.3.5530.9360
United Kingdom	(Toll free) 0800 028 1183
Belgium	(Toll free) 0800 730 41
Israel	073 240 311 8
Rest of world	+ 1 (0) 650 319 884 3
Fax	+ 972 (0) 73 240 311 7
Email to:	support@solaredge.com

www.solaredge.com

solaredge



MAN-01-00067-2.1