

GMS[®] MAX

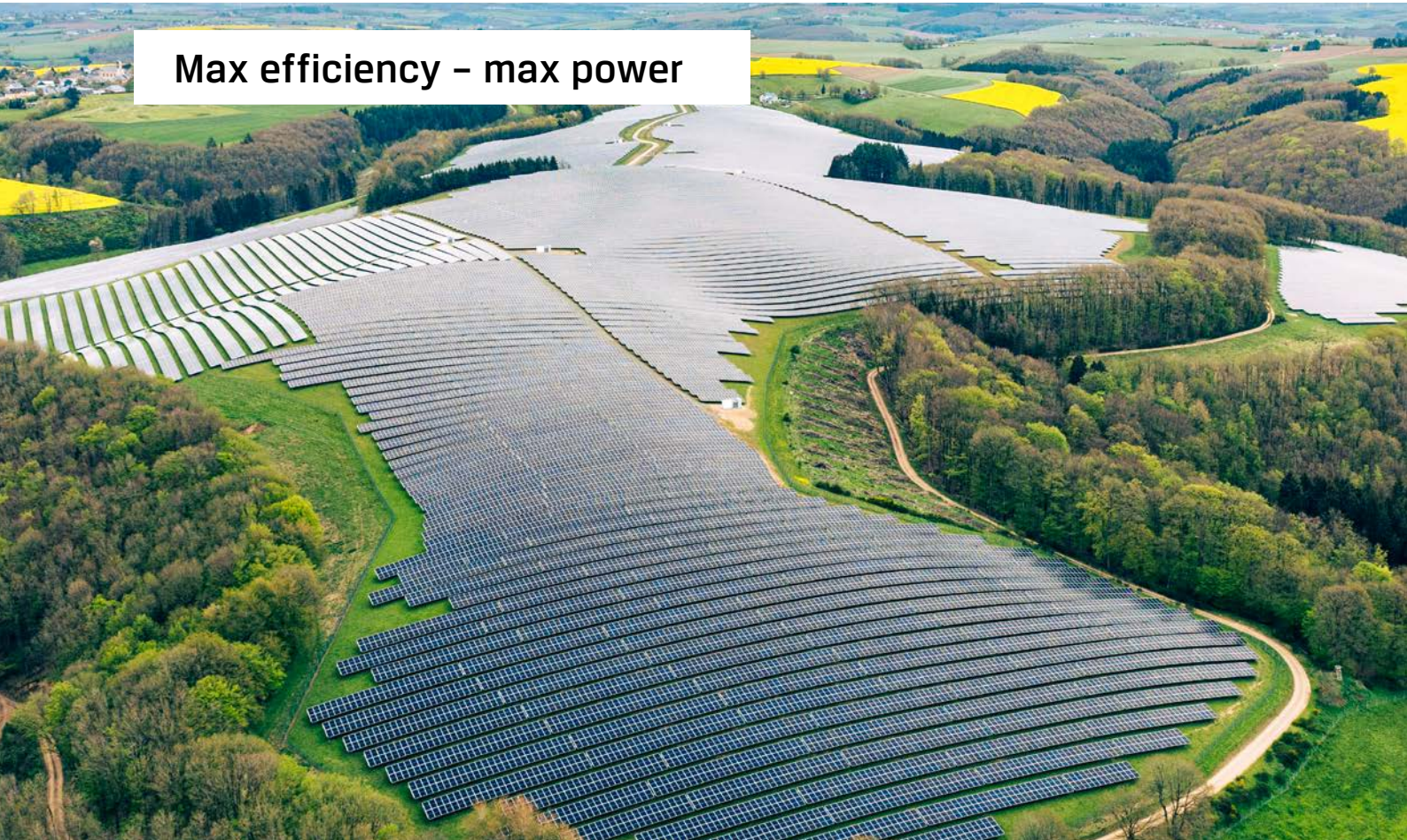

Max efficiency - max power



- / Maximum efficiency
- / Maximum assurance
- / Maximum flexibility
- / Maximum scalability

GMS[®] MAX

Quality, efficiency, reliability, flexibility – this is MKG GÖBEL's DNA.

So it goes without saying that these values have been incorporated into the development of our GMS[®] MAX mounting system. The expertise gathered in numerous projects has enabled us to re-develop ground mounting systems from scratch and optimise them to the maximum.

GMS[®] MAX is convincing thanks to its combination of top quality and efficiency:

vertical and horizontal beams on two rows of posts – no more is required to obtain a stable and cost-effective substructure. Our special heads together with various clamps guarantee the necessary flexibility for designing the project-specific GMS[®] MAX installation. This is complemented by our unique ASSEMBLY 2.0 process (page 5), which enables an unprecedented reduction in installation times and at the same time allows a tighter construction of the area.

2

Discover GMS[®] MAX, the optimum mounting system for your next project.



THE BENEFITS AT A GLANCE

Maximum efficiency

/ Optimised design

The construction has been optimised for bifacial solar modules, with a sophisticated carrier routing along the module frame. Less shadow, more gain.

/ Long lifetime

Very high durability and long-term corrosion protection. Use of aluminium leads to a high terminal value.

/ Standardised components

A small number of standardised components bring together simplicity and flexibility – allowing individual configurations to be implemented.

/ Short shipping routes

Fast and climate-friendly delivery thanks to production in Europe.

/ Efficient care of greenery

The system avoids the need for obstructive bracing underneath, resulting in cost-effective ground maintenance.

Maximum flexibility

/ Adaptation to the terrain

Quick and easy adaption to the ground profile, directly on site: with our flexible adjustment rocker, the system can be tilted sideways up to 8°, in special cases up to 15°.

/ Suitable for any ground type

GMS® MAX provides foundation options for all ground conditions and project-specific requirements, also for aggressive soils.

/ Suitable for all solar modules

Aluminium carriers prevent contact corrosion. The system is compatible with all standard PV modules; quick response to any change or exchange of PV modules.

/ Continuously adjustable components

Stepless fastening ensures great flexibility, especially for dimensional changes (e.g. modules).

Maximum assurance

/ Great stability

Solid construction thanks to closed, torsionally rigid profiles.

/ Secure structural engineering

Project-specific calculation according to the respective norms, ensures structural safety.

/ Secure locking

Safe and precise height adjustment thanks to adaptable components.

/ Open cable installation

Light-weight elements and coordinated cable routing on the substructure offers maximum protection against heat build-up and water accumulation.

/ High quality materials

Only materials of the highest quality are used: posts are piece-galvanised, support elements are made of aluminium, fastening elements are made of stainless steel. Thanks to long-standing partners and carefully selected suppliers, we can guarantee the highest quality standards for your project.

Maximum scalability

/ ASSEMBLY 2.0

The GMS® MAX system can be installed by using the revolutionary mounting process ASSEMBLY 2.0, which further increases the economic efficiency of the system: max installation speed, max soil conservation – in short: max efficiency, especially for megaparks!

/ Maximum use of space

The ASSEMBLY 2.0 procedure allows minimal row spacing, which cannot be realised with conventional installation. This way we ensure optimum utilisation of space and provide a ground and environmentally friendly installation.

/ Flexible assembly workflow

DC assembly is maximally independent of mechanical assembly.

APPLICATIONS

4

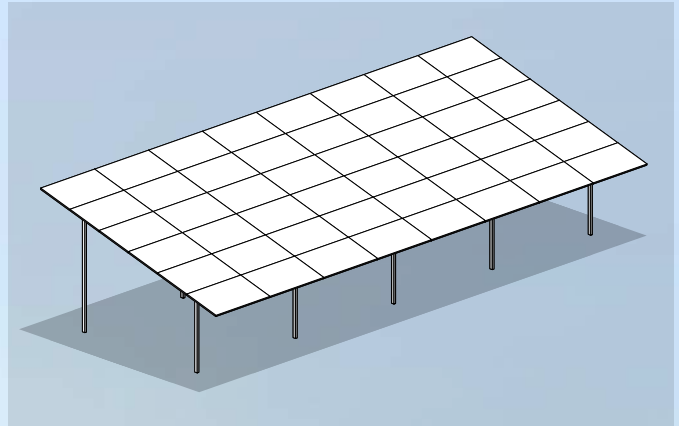
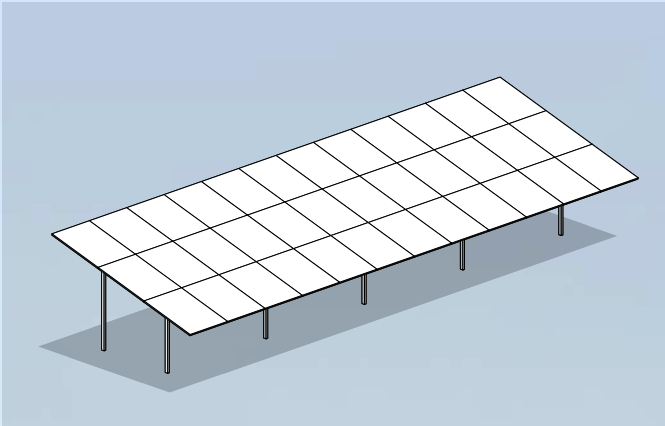

South orientated systems with 2 post rows, 2-4 vertical or 4-6 horizontal module rows

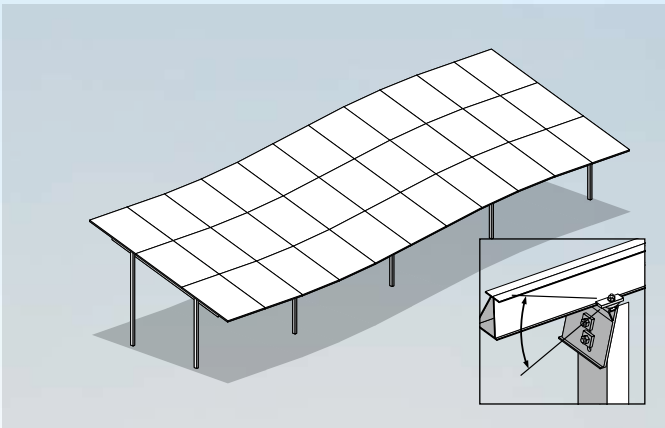

Adaptation to the ground profile

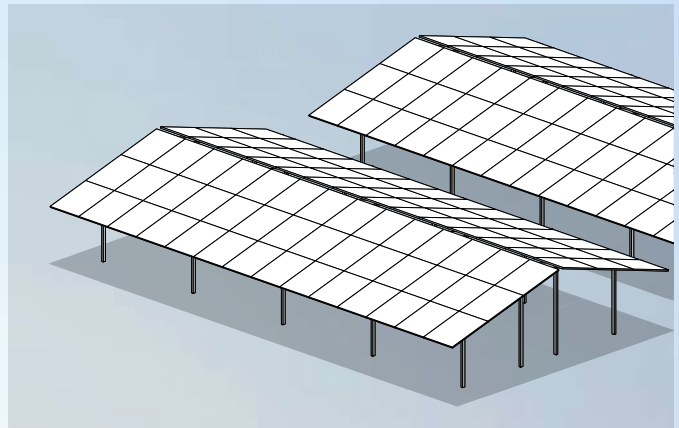

East-west systems vertical / horizontal

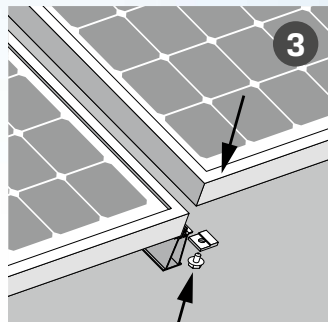
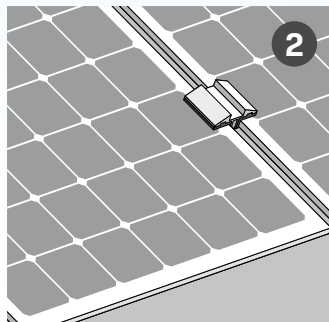
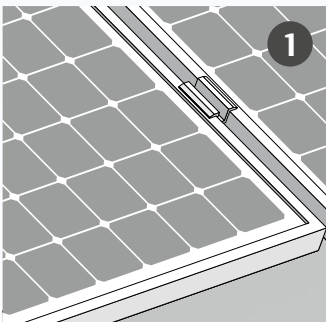

Mounting types: ① framed / ② unframed modules; ③ clamping from downside

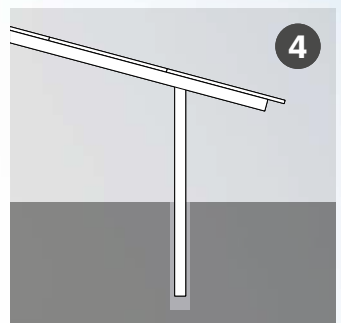
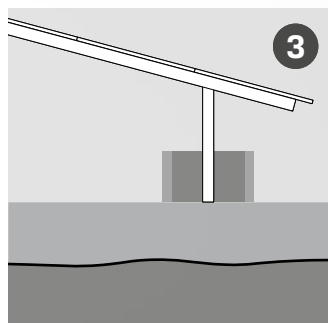
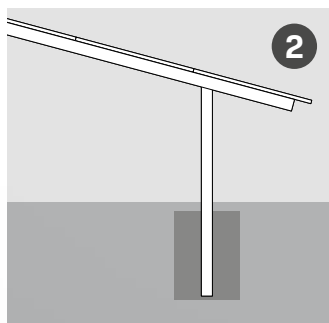
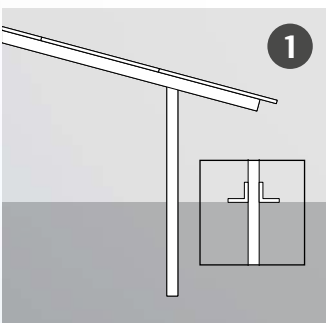

Suitable for any ground conditions with various foundation types:

- ① ram foundation (also with load distribution plates),
- ② single concrete foundation,
- ③ above-ground foundation (e.g. with limited embedment depth),
- ④ drill-holes (in rocky ground)

THE SOLUTION FOR MEGAPARKS

GMS® MAX stands out for maximum efficiency – on any scale. Its design benefits are already evident in smaller PV parks. Added to this is the innovative ASSEMBLY 2.0 process for particularly fast, space-saving and ground-saving assembly. This makes GMS® MAX the perfect platform for state-of-the-art megaparks.

- Scalability: GMS® MAX is designed for solar parks of any size
- ASSEMBLY 2.0 reduces installation times
- Optimum utilisation of space: ASSEMBLY 2.0 allows narrow row spacing
- Soil-friendly installation
- Independent of weather conditions, thus higher reliability in planning
- Optimised on-site logistics save on personnel, fuel, costs and CO₂ emissions



MONTAGE 2.0 in action: The installation of the PV modules is done from the side – they are pushed on as a 'whole table' on rollers.



MAIN VARIANTS

Vertical version

The module carriers run along the PV module frame. They are attached to the long side of the modules with clamps.

This configuration is perfect for bifacial PV modules. As the carriers run laterally, the bifacial effect can be utilised across the entire surface without restriction.

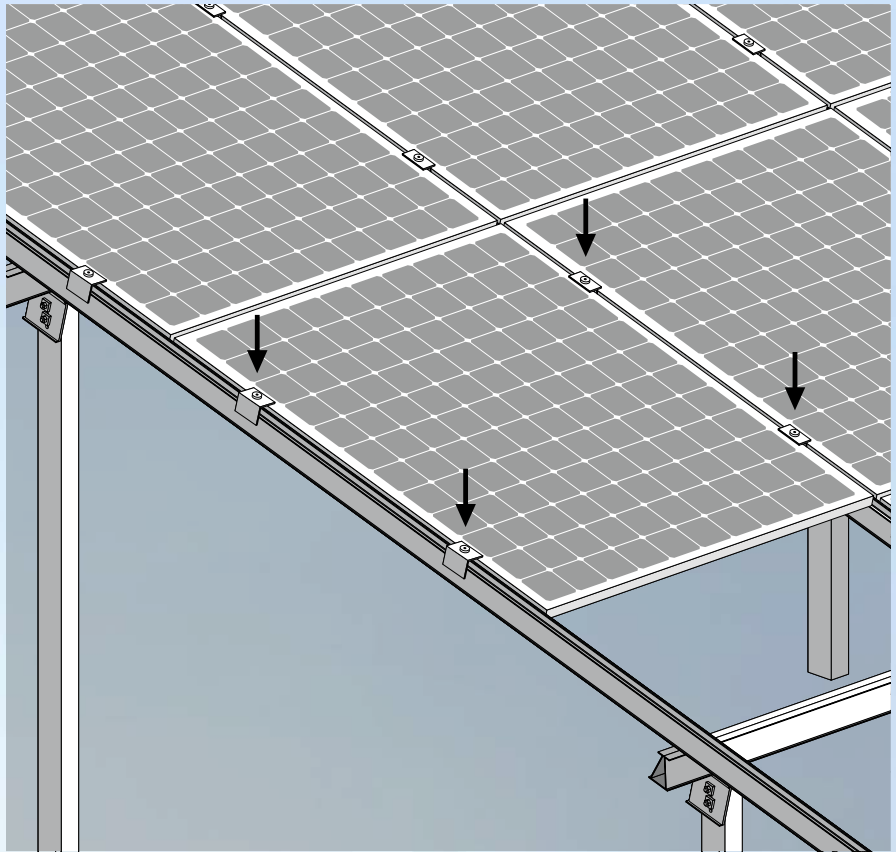

6

- / Main variant: 3 modules vertical (max. 4 modules vertical)
- / Variable carrier dimensions, matched to all standard PV modules
- / Inclination 5 to 25°
- / ASSEMBLY 2.0

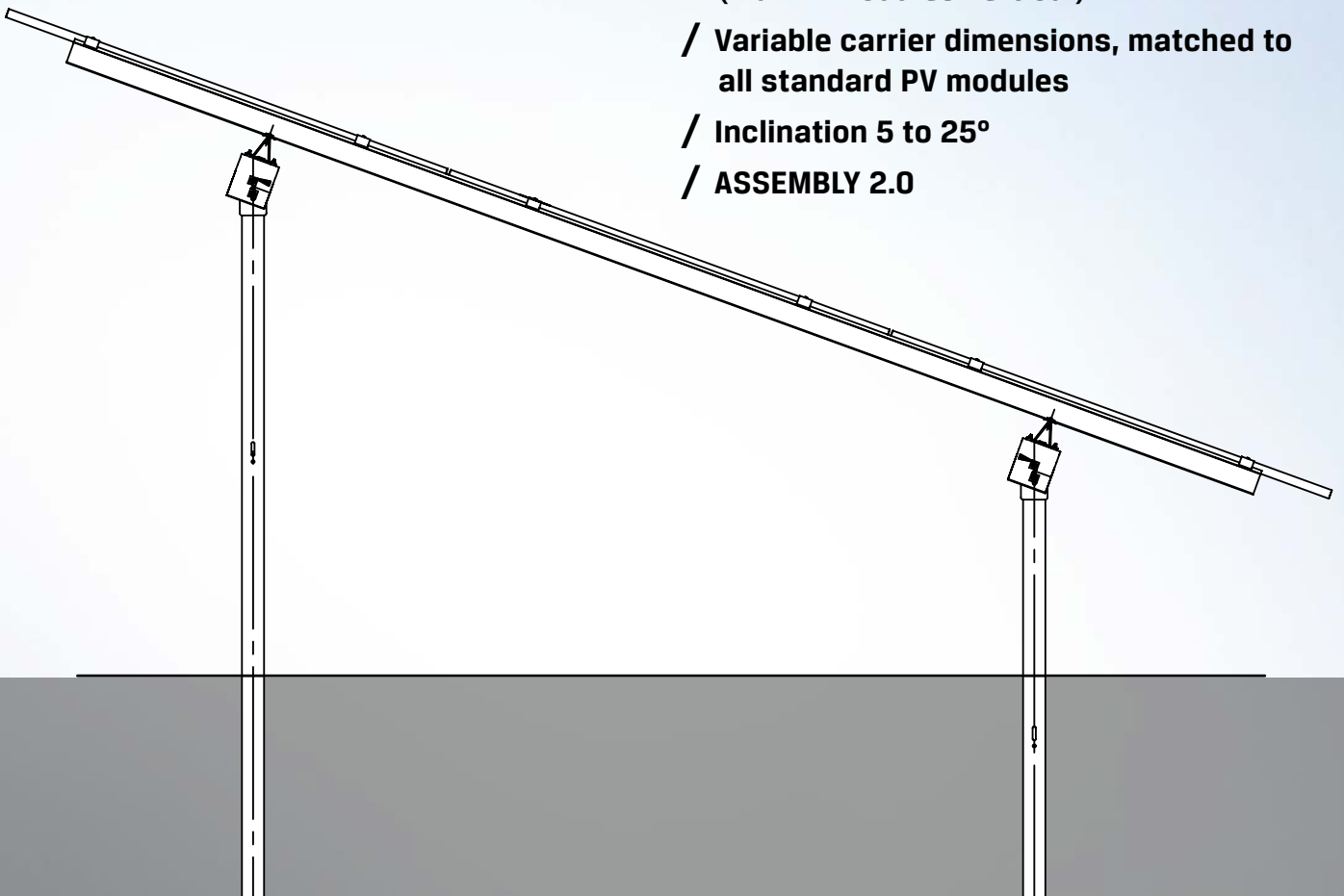

Horizontal version

The module carriers run beneath the PV modules. The modules are attached with clamps at the long side.

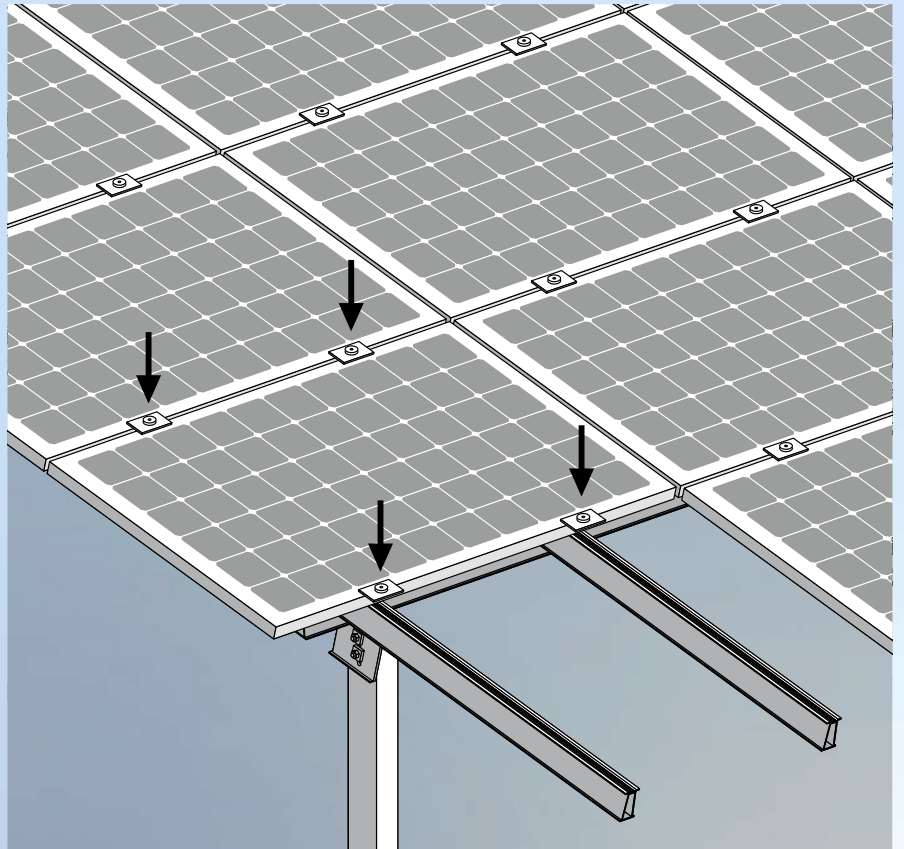

7

- / Main variant: 6 modules horizontal
- / Variable carrier dimensions, matched to all standard PV modules
- / Inclination 5 to 25°

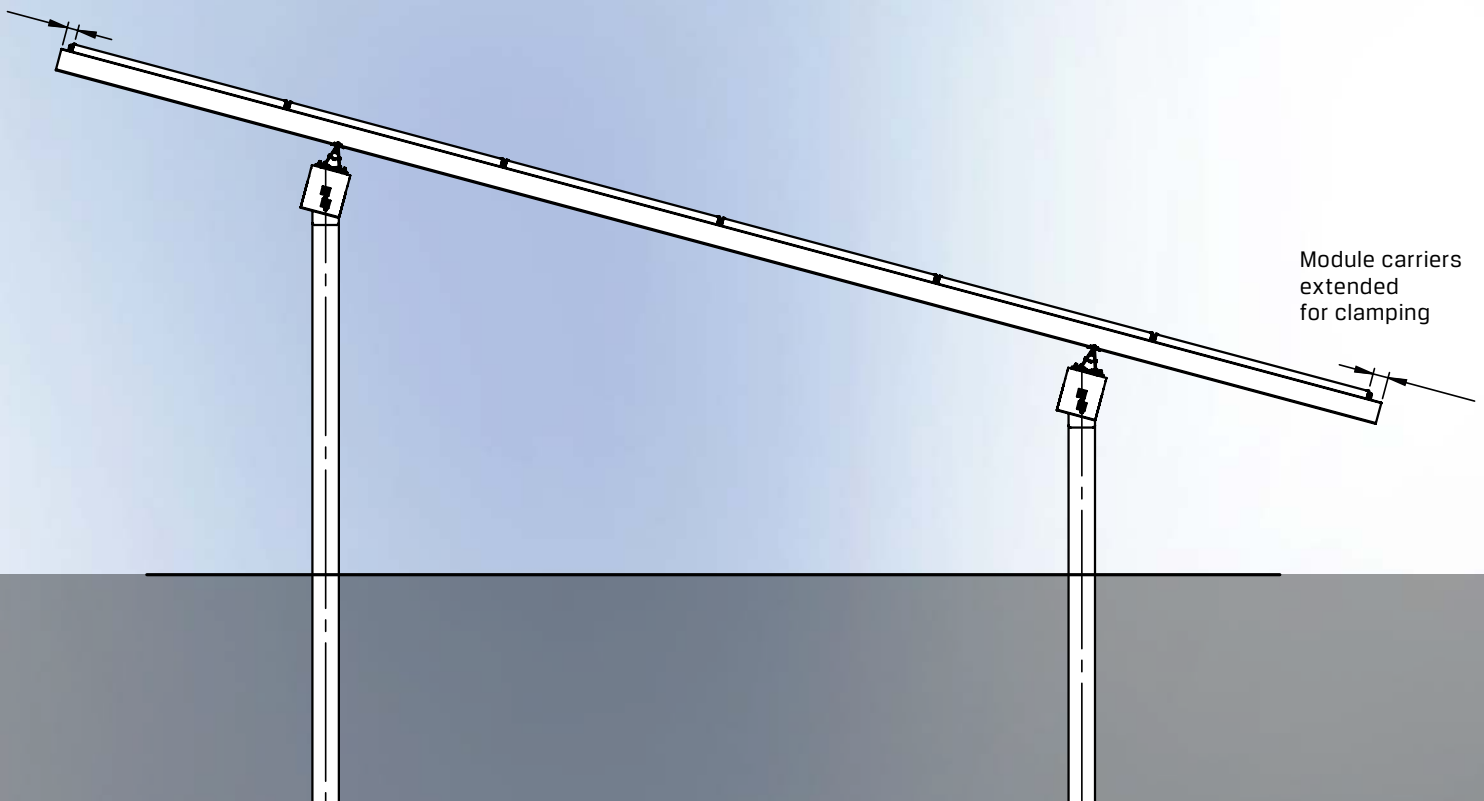

Module carriers
extended
for clamping

MAIN COMPONENTS

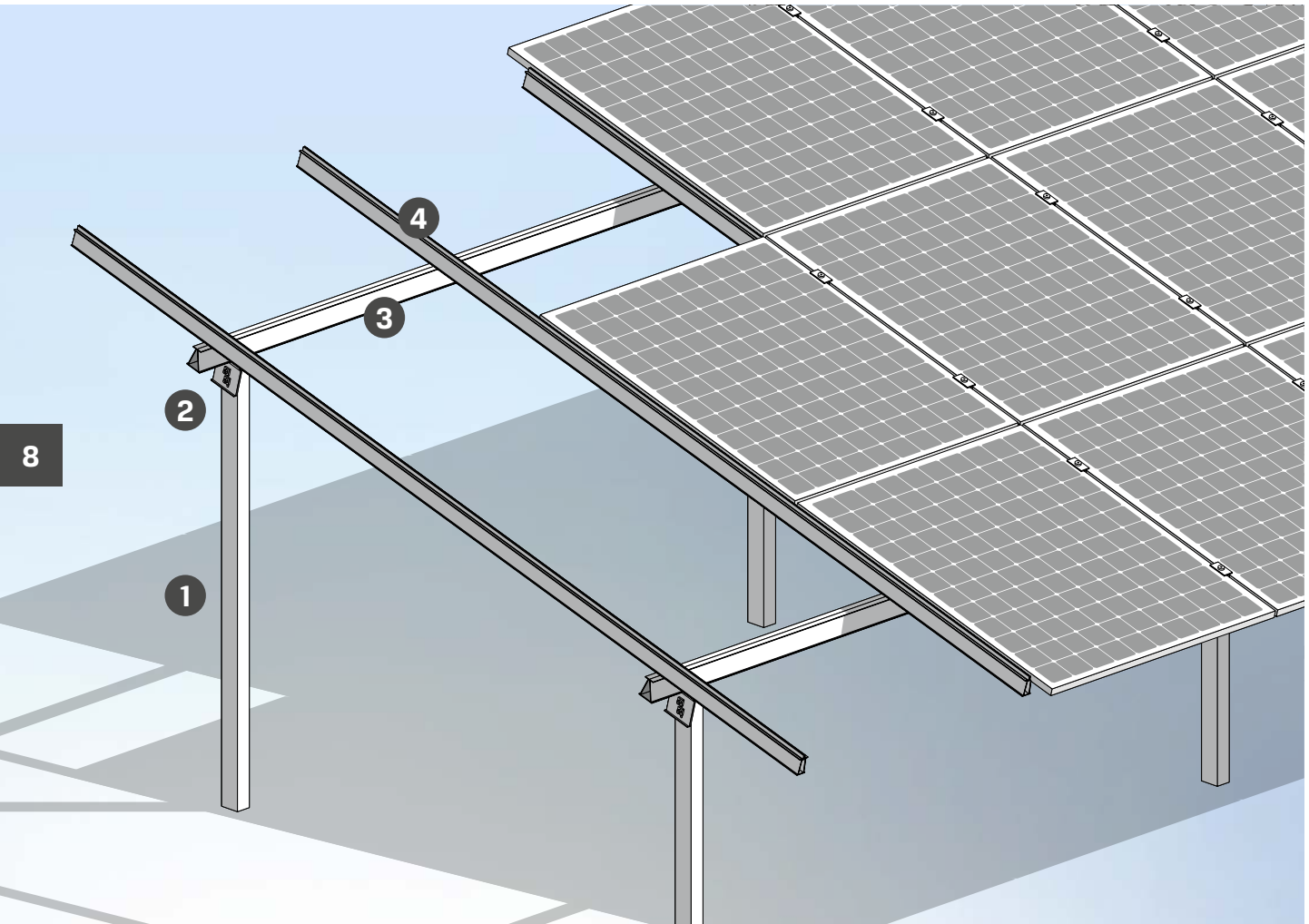

1. Posts

Corrosion-resistant, hot-dip galvanised C-profiles offer maximum flexibility for the most varied ground conditions.

2. Heads

The ribbed structure of the special head enables variable and safe height adjustment of approx. 50 mm.



3. Long beams

Closed aluminium long beams offer excellent stability.

4. Module carriers

Optimised module carriers made of aluminium guarantee the ideal support and fastening of the modules.



ACCESSORIES

Cable management

Cable trays along the long beam for clipping ("cable channel light")

Cable clamps for module cables



Potential equalisation / lighting protection

Bridging strap for potential equalisation between the tables

Middle clamp with earthing pins

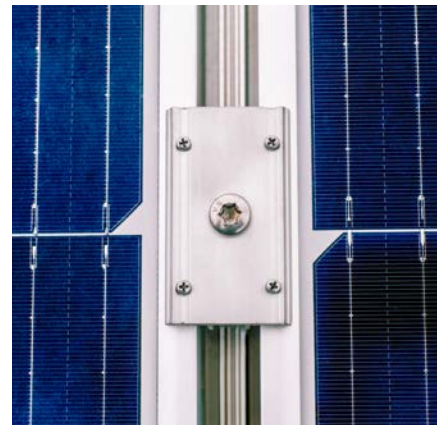

9

Inverter mounting

Bracket for string inverters or string combiner boxes (SCB)

Bite protection cage



Safety

Theft prevention:
screw head protection with dual-component adhesive

Protection for sharp edges

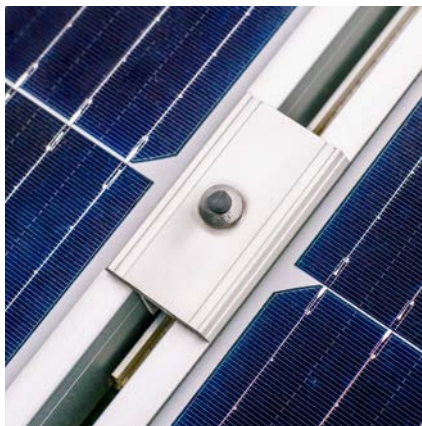

LANDFILL SITES

Landfill sites can additionally be used with solar parks. The problem is the limited depth of the top layer as well as the sensitive sealing membrane underneath, which needs to be protected under any circumstances. With GMS® MAX, MKG GÖBEL provides the perfect mounting system and also has already realised a number of plants on landfill sites.

- Embedment depth of 80 cm, depending on landfill requirements and depth of the surface layer
- Slope parallel construction is possible, even with varying terrain inclinations
- Side inclinations up to 15° (on slopes, south-orientation)
- Above-ground cable routing is possible
- ASSEMBLY 2.0 procedure protects the turf
- Erosion protection: erosion insensitive foundation, controlled water distribution
- Foundation can be made with split posts optionally to compensate ground settlements afterwards

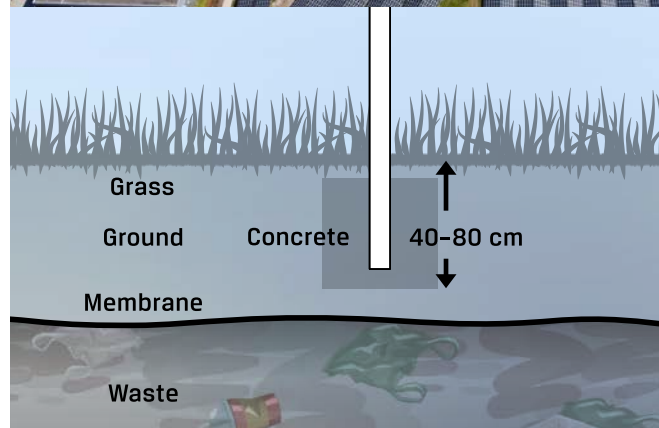

PEATLANDS

In some cases, solar parks are built in areas such as swamps or wet meadows, where the soil characteristics place special demands on the construction. Also here, GMS® MAX offers a number of benefits:

- Where the peat layer offers no support, it is penetrated; the foundation is laid in the load-bearing soil below
- Execution with split posts possible, with enormous pile-driving depth
- Posts with special coating as corrosion protection
- Above-ground cable routing is possible
- Built-on peatlands continue to provide a habitat for various plant and animal species
- ASSEMBLY 2.0 procedure protects the turf
- Erosion protection: erosion insensitive foundation, controlled water distribution



SLOPE INSTALLATIONS

With their intense sunlight, hillside locations offer good conditions for photovoltaic power plants, but the steep ground poses a special challenge. Therefore, trust into MKG GÖBEL's know-how and expertise.

- Geological soil survey and 3D modelling, also for difficult terrains
- Planning: your plant designed for maximum sun-radiation optimisation
- Thanks to its flexibility, GMS® MAX is easy to adapt to the ground profile
- Installation with suitable machines, e.g. slope pile drivers
- ASSEMBLY 2.0 is possible on hillsides
- Worldwide project experience



11

AGRI PV

Double use: With raised PV modules, the space underneath can also be used for agricultural purposes (crop cultivation, animal farming). The system is also suitable for use in flood or inundation areas.

- Complies with DIN SPEC 91434 and 91492
- ASSEMBLY 2.0
- Standard height of the lower edge: 2.20 m
- Height differences can be compensated using adjustment rockers and split posts



TECHNICAL DATA

Foundation	<ul style="list-style-type: none">• Rammed posts• Single concrete foundation• Above-ground foundation	<ul style="list-style-type: none">• Drill holes• Load distribution plates
Construction	Modular system with just 4 main components	
Material	<ul style="list-style-type: none">• Posts: hot-galvanised steel (batch galvanised – EN ISO 1461)• Heads, long beams, module carriers: aluminium EN AW 6063 T66• Fastening elements: stainless steel 1.4301	
Structural calculation	Project specific, complies with Eurocode DIN EN 1991, DIN EN 1993, DIN EN 1999, wind tunnel test, CC2, load return period 50 years	
Type of modules	Vertically 2 – 4 modules, Horizontally 3 – 6 module rows	
Module inclination	Flexible angle of inclination Standard: 5° to 25° (other angles on request)	
Terrain adaption	North/South-inclination: up to ± 45° (other angles on request) East/West-inclination: up to ± 8° (with adjustment rockers)	
Accessories	<ul style="list-style-type: none">• Cable channels light• Cable clamps• Bridging straps• Middle clamps with earthing pins• Mounting brackets for inverters or string combiner boxes (SCB)	<ul style="list-style-type: none">• Bite protection cages• Theft prevention with dual-component adhesive• End caps for long beams

Technical data subject to change without notice

SERVICES

Service package 1

GMS® MAX

- Ground survey via test pile driving
- Project planning, incl. auditable structural report of the system
- Delivery of the mounting system to the construction site

Service package 2

+ Mechanical installation

- All services package 1, plus
- Unload/distribute material
 - Ramming and foundations
 - Mounting of substructure
 - Mounting of modules (except electrics)
 - MKG GÖBEL site managers

Service package 3

+ DC installation

- All services package 1+2, plus
- Stringing module cables, joining connector pairs, etc.
 - DC cable run to inverter
 - Inverter installation
 - DC tests

MKG GÖBEL

MKG Göbel Solutions GmbH

Pfaffenmühlweg 86
74613 Öhringen, Germany
Phone: +49 (0) 79 41-6 49 20-0
Telefax: +49 (0) 79 41-6 49 20-20
E-mail: info@mkg-goebel.de

www.mkg-goebel.de

Certified according to
DIN EN ISO 9001:2015



Industrial safety certified
ISO 45001:2018 and SCC



S ICHERHEITS
C ERTIFIKAT
C ONTRAKTOREN