

# INSTALLATION INSTRUCTIONS FOR THE PLANNING AND INSTALLATION OF A SOLARFOX<sup>®</sup> DISPLAY

The following information will provide a brief overview for installing a Solarfox<sup>®</sup> displays. The instructions are aimed particularly at installers and planners.

## Table of contents

1.	Time and cost estimate .....	2
2.	Work steps .....	2
3.	Assembly variants in indoor and outdoor applications .....	3
4.	Connectors .....	3
5.	Data communication and network integration .....	5
6.	Checklist .....	6
7.	Technical specification for wall mounting and dimensions .....	7
8.	Interfaces / compatible monitoring systems .....	10
	Interface overview (Systems which are compatible with Solarfox <sup>®</sup> ) .....	10
9.	Connection of old systems and photovoltaic systems with no data logger .....	10
10.	Display commissioning with subsequent commissioning of the data source .....	10
11.	Connection of additional systems and data sources .....	11
12.	Timing and power saving feature .....	11
13.	Maintenance .....	11
14.	Warranty .....	11

## 1. Time and cost estimate

The following calculation helps you calculate the cost of installing a Solarfox<sup>®</sup> display and plan. The following calculation assumes that electricity and network connection (LAN or WLAN) are already available at the installation location.

Operation
1) Drill four holes and attach the anchor
2) Installation of the wall mount plate
3) Installation of the display and connection of the power and LAN cables
4) Registration of the display under <a href="http://setup.solar-fox.com">http://setup.solar-fox.com</a> (it should be performed on any computer via the Web form even before installation) the access data is immediately sent to you from the system via email.
5) Implementation of display setup and configuration of the Solarfox <sup>®</sup> display using a USB keyboard

For a quick and smooth installation and commissioning of the Solarfox<sup>®</sup> display we recommend an installation in advance to coordinate all necessary information with the IT managers (Administrator). To do this, use our Checklist (point 11). This ensures that an Internet connection and all the necessary data are available on site.

## 2. Work steps

For the installation of a Solarfox<sup>®</sup> display we recommend the following steps:

- 1) Registration of the display under <https://setup.solar-fox.com> with the serial number
- 2) Preparation of the connections to the installation location
- 3) Installation of the display
- 4) Configuration of the display
- 5) User can access the online management of the display from any computer with Internet access

### 3. Assembly variants in indoor and outdoor applications

- I) On-site installation options for indoor Solarfox<sup>®</sup> SF-300 displays:
- (1) Wall mounting by a tilting wall mount (included)
  - (2) Ceiling mounting using a ceiling mount (accessory)
  - (3) Two leg or one leg stand foot - height 180 cm (accessory)
  - (4) Stands for display placement E.g. shelf or sideboard (accessory)
  - (5) Installation in a window - with ceiling or floor stand (accessory)
  - (6) Mounting with a swivel holder which can be adjusted horizontally and vertically (accessory)
- II) On-site installation options for outdoor Solarfox<sup>®</sup> SF-600 displays:
- (1) Wall mounting with wall holder
  - (2) Display orientation: East, West, North, South
  - (3) Free-standing mounting on stand and concrete foundation

### 4. Connectors

- 2 x power socket (230V) (It is also possible to use a multiple socket outlet)
- 1 x RJ45 network (Ethernet) connection (cable: CAT5e) or Wi-Fi (SF-300)

Instead of a network connection via Ethernet cable, it is possible to use a Wi-Fi network.

Alternatively, a UMTS router can also be used for a mobile radio connection. A flat rate is required. The traffic depends on the content and the refresh rate of your slideshow. We recommend therefore a flat rate or a rate with 2-5 GB volume. (Please check reception quality on the spot!)

The sockets can be provided behind the display in an outlet area of the wall bracket, we recommend two lower wall sockets. The recess is to install sufficient to the sockets in this way invisible to the wall or behind the display. On the spot only a wall outlet or power supply connection should exist, the second line can be powered using a standard extension (PDU).

## Connection plan Solarfox<sup>®</sup> display (example)

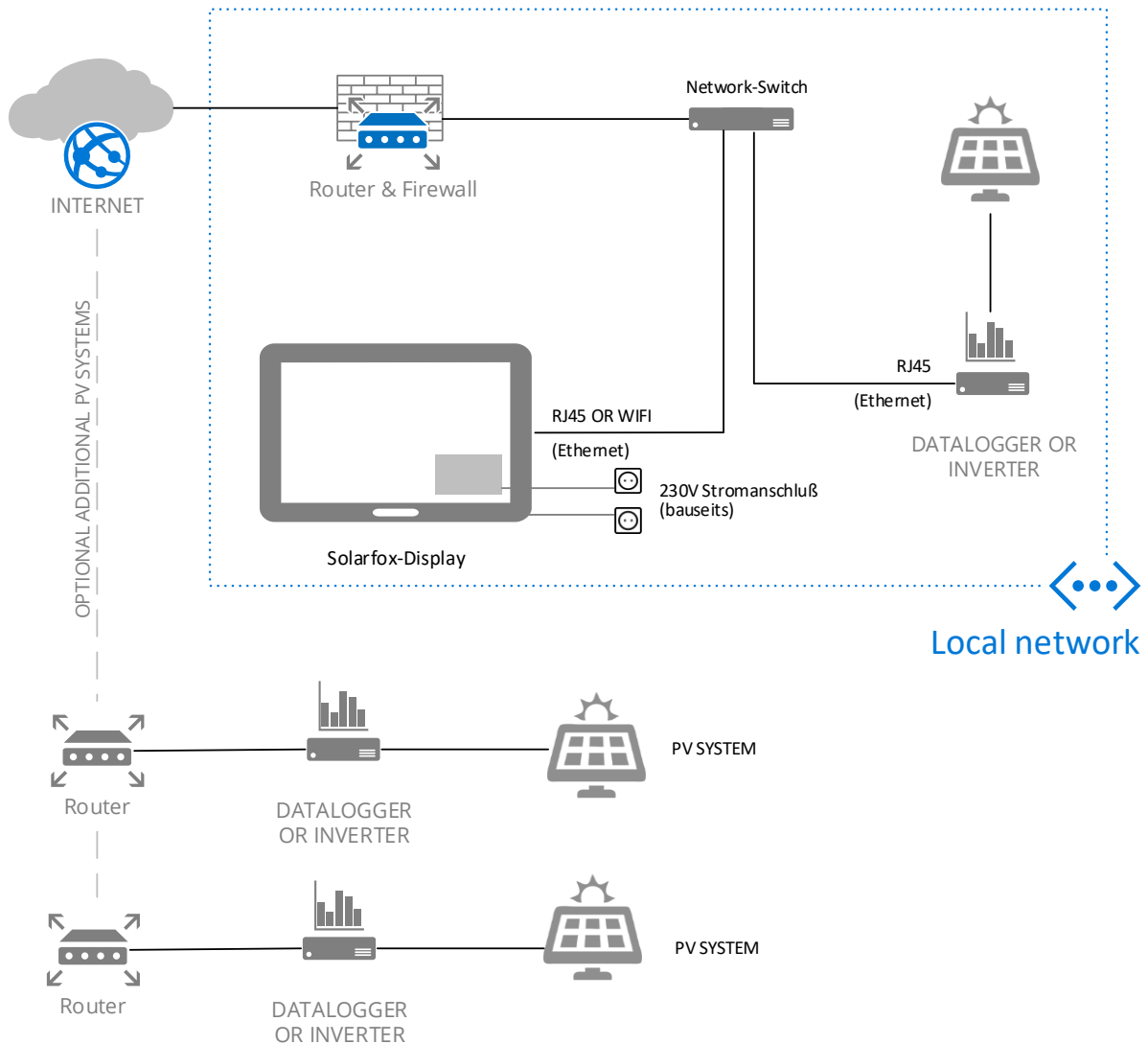

The data connection to the photovoltaic system is always done via the Web interface. By so doing, you are completely independent of location and very flexible as well. (**See section 5**)

## 5. Data communication and network integration

An Internet connection is required for the operation of the Solarfox<sup>®</sup> display. In order to do this, the display gets of yield data from the Solarfox<sup>®</sup> Web server at regular intervals. You will find below all information that are important for the data connection in company or agency networks. Please ensure a corresponding port forwarding or port sharing for the listed IP addresses. Other firewall rules are not required. There is only a data retrieval. A data upload is not on the device. If you change the display content is the data modification on the part of the Web server. The Solarfox<sup>®</sup> display gets data from the Internet or from the Solarfox<sup>®</sup> Web server only. This ensures high reliability.

Information for the network integration	
<b>Network:</b>	LAN, WLAN, UMTS (3G)
<b>Connectivity:</b>	Dynamic IP-Address (DHCP) or static IP-Address
<b>URL:</b>	show.solar-fox.com
<b>IP:</b>	212.224.82.131 (Solarfox <sup>®</sup> Slideshow 2.x) 212.224.82.132 (Solarfox <sup>®</sup> Slideshow 2.x - Status) 212.224.82.155 (Solarfox <sup>®</sup> Update Service - Firmware)
<b>Port:</b>	80, 443
<b>Proxy server:</b>	optional

Information for network administrators can be found at <https://solar-fox.com/en/download.html>

## 6. Checklist

### Checklist for installing Solarfox<sup>®</sup> display systems

---

The following checklist can be used to clarify important framework data, requirements and questions in advance before installing a Solarfox<sup>®</sup> display.

Date:	
-------	--

#### 1) General information about the property / building:

Name of the property:	
Property number:	
Street:	
Postal code and city:	
Contact person:	
Tel:	
E-Mail:	

#### 2) Information about existing connections for the Solarfox<sup>®</sup> display

	Yes	No
Is there a possibility of accessing the Internet? (LAN/WLAN/etc.)	<input type="checkbox"/>	<input type="checkbox"/>
Does it consist of a power connector with 2 Sockets at installation?	<input type="checkbox"/>	<input type="checkbox"/>

#### 3) Data supervision / monitoring

What energy sources should be visualized? What data loggers / counters are available?

Renewable energy system (PV, wind, cogeneration, etc.)	Power kW
Photovoltaic system:	

#### 4) Installation of display and data logger

	Yes	No
Has a data logger / monitoring already been installed?	<input type="checkbox"/>	<input type="checkbox"/>
Does the data logger transfer data on the Internet already?	<input type="checkbox"/>	<input type="checkbox"/>
Which data logger or monitoring system is concerned?		

## 7. Technical specification for wall mounting and dimensions

### Wall panel's wall mount for Solarfox® SF100 / SF-300 24" and 32"

The carrier plate is wall mounted and then holds on the display with the inclinable carrier. Please select the appropriate screws and anchors for your wall (Please pay attention to the weight (see table). These are not included in delivery.

The compact dimensions of the wall mount allow for an easy and flexible installation of electrical outlets in the side portion of the mount and thus behind the display, so that they are no longer visible after the display assembly.

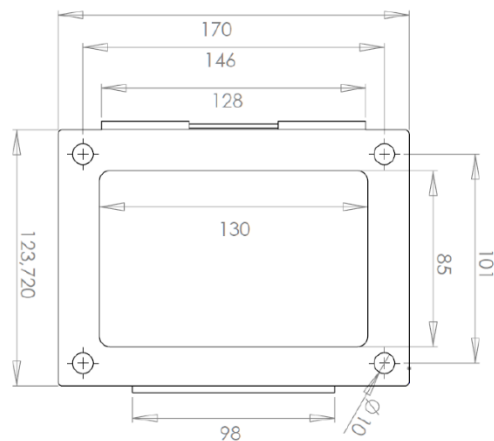

### Wall plate's wall mount for Solarfox® SF-300 43" to 75"

The carrier plate is wall mounted and then holds the display with inclinable carriers. Please select the appropriate screws and anchors for your wall. Please pay attention to the weight (see table). These are not included in delivery. Flush sockets (1 x LAN, 2 x 230 V) can be placed in the two middle free surfaces.

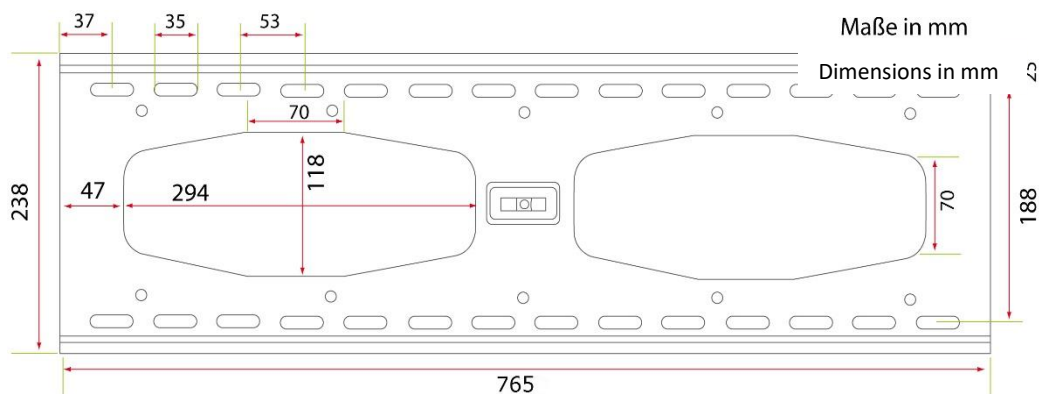

### Solarfox<sup>®</sup> SF-100 Serie: display dimensions and weight

Display	Length	Width	Depth with Wall mount	Weight
<b>SF-100 24"</b>	539 mm	322 mm	39 mm	3,6 kg
<b>SF-100 32"</b>	725 mm	420 mm	89 mm	6,7 kg

### Solarfox<sup>®</sup> SF-300 Series: display dimensions and weight

Display	Length	Width	Depth with Wall mount	Weight
<b>SF-300 24"</b>	539 mm	322 mm	39 mm	3,6 kg
<b>SF-300 32"</b>	725 mm	420 mm	89 mm	6,7 kg
<b>SF-300 43"</b>	967 mm	557 mm	103 mm	10 kg
<b>SF-300 50"</b>	1112 mm	644 mm	101 mm	13,4 kg
<b>SF-300 55"</b>	1235 mm	708 mm	101 mm	18,1 kg
<b>SF-300 65"</b>	1454 mm	831 mm	101 mm	24,9 kg
<b>SF-300 75"</b>	1681 mm	960 mm	104 mm	38,3 kg

### Solarfox<sup>®</sup> SF-600 Series: display- dimensions and weight

Display	Length	Width	Depth with Wall mount *	Weight
<b>SF-600 46"</b>	1069 mm	623,6 mm	127 mm	40,5 kg
<b>SF-600 55"</b>	1260 mm	731,4 mm	127 mm	56,2 kg

\* The fan covers are also attached on the back. These have the same depth as the wall mountings but are not shown in the drawings below. They each put 40 mm at the top left and right.

**Caution:** In case you plan to place the display on a wall, you should check the exact dimensions once again with our sales. Due to model changes, slight deviations of components may occur temporally.



### Technical drawing: Wall mount SF-600 46"(Outdoor-Serie)

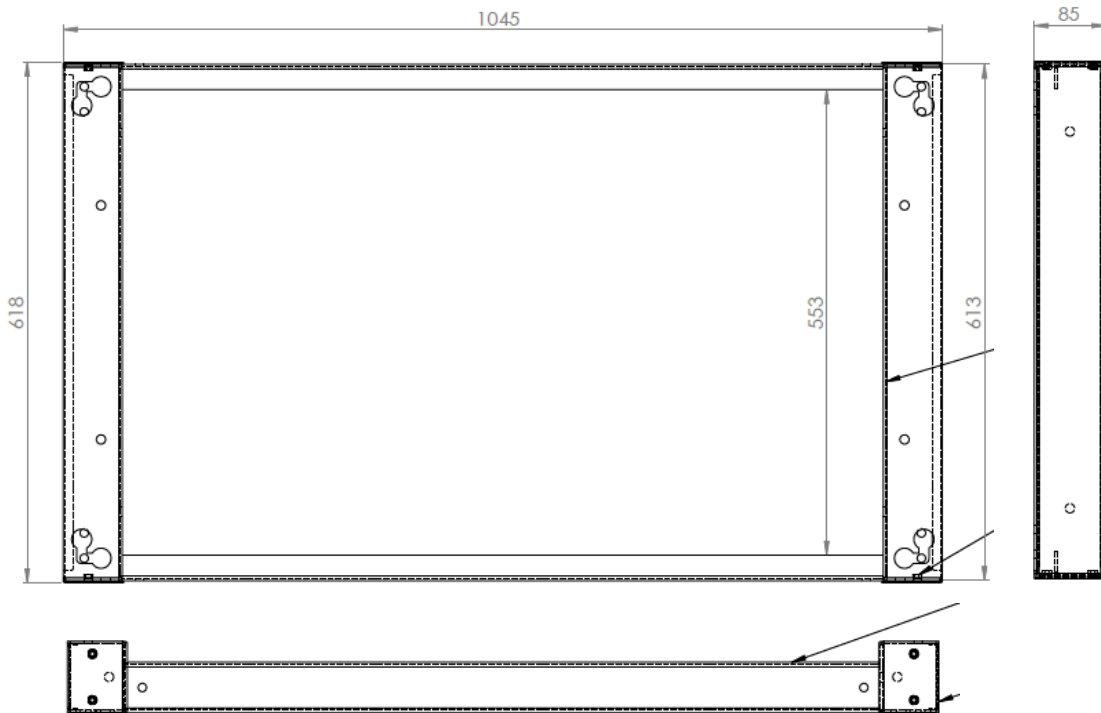

A manual for the SF-600 series can be found under  
<https://www.solar-fox.com/en/solarfox-sf-600-solar-displays.html>

### Technical drawing: Wall mount SF-600 55"(Outdoor-Serie)

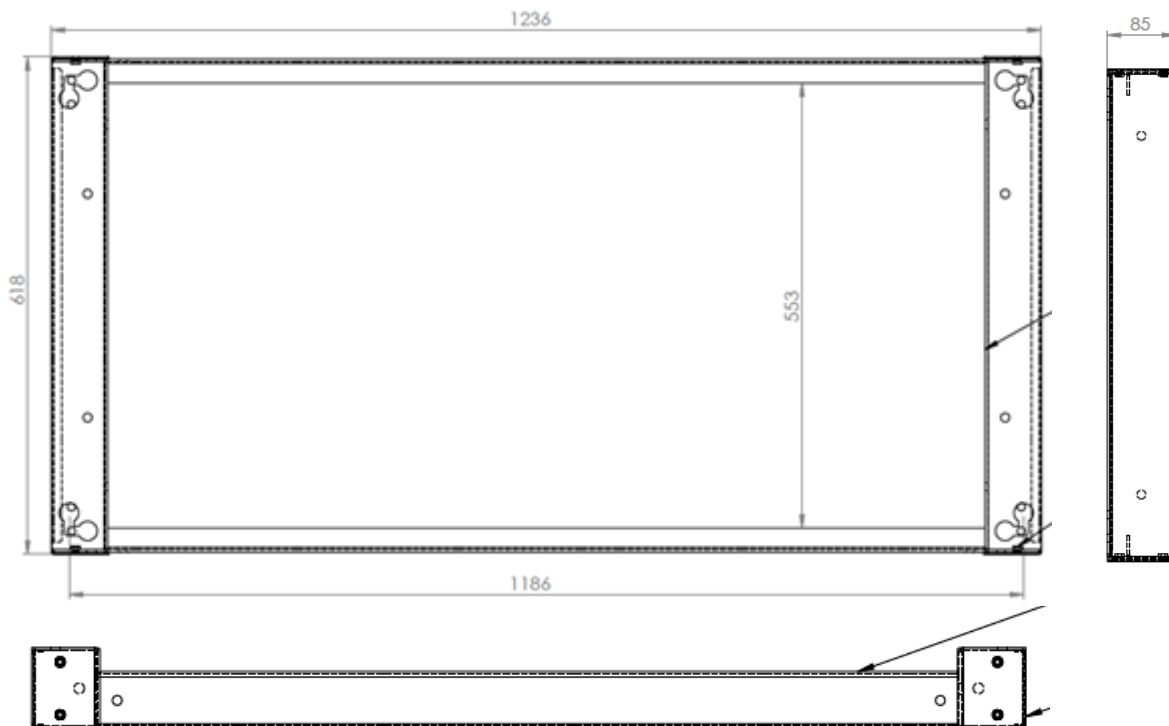

## 8. Interfaces / compatible monitoring systems

### Interface overview (Systems which are compatible with Solarfox<sup>®</sup>)

A current list of available interfaces can be found under  
<https://www.solar-fox.com/en/datalogger-interfaces.html>

**Attention:** Most of the Solarfox<sup>®</sup> data interface are free of charge. SMA and Fronius provide energy data only via the additional Data-Update-Service for which a fee is charged. Please see the following link for more information:  
<https://solar-fox.com/data-update-service>

## 9. Connection of old systems and photovoltaic systems with no data logger

In some cases, there is no connection point of the display on the photovoltaic system in the desired location or no data can be provided by the system. This can have the following reasons for example:

- 1) There is no data logger available
- 2) There is an old data logger without Internet available
- 3) The data logger is not fitted with an Internet connection
- 4) The data logger is the property of system operator and no data access allowed

In the case of the above mentioned constellations, the system data can be simulated also. In this case, Solarfox<sup>®</sup> draws on regional radiation values or plant data of a comparable plant and approximately calculates the yield of your system using an algorithm. Accordingly, we need only the plant size and alignment of the concerned units. Then the Solarfox<sup>®</sup> even without a connection to your system can approximately display the yield data. The deviation of income moves only in the lower single digits. The data can be adapted at any time but also in our system online identified deviations and edited.

## 10. Display commissioning with subsequent commissioning of the data source

We recommend the installation or online registration of the Solarfox<sup>®</sup> display only after the data logger has been put into operation, and if the photovoltaic system has once had to transfer data. This speeds up the installation process. You can also independently register the Solarfox<sup>®</sup> display no data source and first unlock this without data source. Transitional can operate the display no data source or unlock a demo system and unhide.

## 11. Connection of additional systems and data sources

After commissioning, you can add any more data sources to a Solarfox<sup>®</sup> display. You need only an appropriate data sources package, which must be unlocked. In this way, photovoltaic systems, wind power plants, CHP or other equipment can be added.

## 12. Timing and power saving feature

Solarfox<sup>®</sup> displays have a built-in timer, which allows individual day at a certain time to turn on the display and turn off at a specified time. In this way the appliance can be adapted energy-efficient to the desired service life.

## 13. Maintenance

If you are mounting the display on a ceiling or higher than 2 m, you should provide a USB extension cable. Connect it to the control computer and attach these in form coiled up behind the display. You can use them in case of a service for connecting a keyboard.

## 14. Warranty

The warranty is 36 months. Depending on the warranty, a replacement or the processing by Pick-Up & return service is carried out. More information, please refer to our warranty conditions.

You can find more information under <https://www.solar-fox.com/en/solarfox-terms-and-conditions.html>